

CONTENTS

1 Scope4

2 Normative references4

3 Terms, definitions, symbols and dimensions.....5

4 General conditions for measurements7

5 MEASUREMENT EQUIPMENT AND ACCURACY.....8

6 TEST PROCEDURES9

7 Sample Sizes for Tests..... 11

8 TEST REPORT..... 12

(Normative)24

INTERNATIONAL ELECTROTECHNICAL COMMISSION

**SELF-BALLASTED COMPACT FLUORESCENT LAMPS –
METHODS FOR MEASURING THE PERFORMANCE**

FOREWORD

- 1) The International Electrotechnical Commission (IEC) is a worldwide organization for standardization comprising all national electrotechnical committees (IEC National Committees). The object of IEC is to promote international co-operation on all questions concerning standardization in the electrical and electronic fields. To this end and in addition to other activities, IEC publishes International Standards, Technical Specifications, Technical Reports, Publicly Available Specifications (PAS) and Guides (hereafter referred to as "IEC Publication(s)"). Their preparation is entrusted to technical committees; any IEC National Committee interested in the subject dealt with may participate in this preparatory work. International, governmental and non-governmental organizations liaising with the IEC also participate in this preparation. IEC collaborates closely with the International Organization for Standardization (ISO) in accordance with conditions determined by agreement between the two organizations.
- 2) The formal decisions or agreements of IEC on technical matters express, as nearly as possible, an international consensus of opinion on the relevant subjects since each technical committee has representation from all interested IEC National Committees.
- 3) IEC Publications have the form of recommendations for international use and are accepted by IEC National Committees in that sense. While all reasonable efforts are made to ensure that the technical content of IEC Publications is accurate, IEC cannot be held responsible for the way in which they are used or for any misinterpretation by any end user.
- 4) In order to promote international uniformity, IEC National Committees undertake to apply IEC Publications transparently to the maximum extent possible in their national and regional publications. Any divergence between any IEC Publication and the corresponding national or regional publication shall be clearly indicated in the latter.
- 5) IEC provides no marking procedure to indicate its approval and cannot be rendered responsible for any equipment declared to be in conformity with an IEC Publication.
- 6) All users should ensure that they have the latest edition of this publication.
- 7) No liability shall attach to IEC or its directors, employees, servants or agents including individual experts and members of its technical committees and IEC National Committees for any personal injury, property damage or other damage of any nature whatsoever, whether direct or indirect, or for costs (including legal fees) and expenses arising out of the publication, use of, or reliance upon, this IEC Publication or any other IEC Publications.
- 8) Attention is drawn to the Normative references cited in this publication. Use of the referenced publications is indispensable for the correct application of this publication.
- 9) Attention is drawn to the possibility that some of the elements of this IEC Publication may be the subject of patent rights. IEC shall not be held responsible for identifying any or all such patent rights.

International Standard IEC 60456 has been prepared by subcommittee 59D: Home laundry appliances, of IEC technical committee 59: Performance of household electrical appliances.

This fourth edition cancels and replaces the third edition published in 1998 and constitutes a technical revision.

The text of this standard is based on the following documents:

FDIS	Report on voting
59D/239/FDIS	59D/246/RVD

Full information on the voting for the approval of this standard can be found in the report on voting indicated in the above table.

Experience with the use of the third edition of IEC 60456, together with some revised test conditions and a common **base load** with IEC 61121 are the reasons for this fourth edition.

SELF-BALLASTED COMPACT FLUORESCENT LAMPS – METHODS FOR MEASURING THE PERFORMANCE

1 Scope

This International Standard specifies the test methods and conditions required for self-ballasted, compact fluorescent lamps (single ended tubular fluorescent lamps), with integrated means for starting, controlling and stable operation.

This Standard is applicable for self-ballasted CFLs of all voltages and wattages irrespective of the type of lamp cap. This standard excludes cold cathode and non-general purpose lighting CFLs.

This Standard further specifies test methods for the following:

- a) Efficacy.
- b) Starting time.
- c) Low temperature starting (NEW).
- d) Run-up time.
- e) Lumen maintenance.
- f) Lamp life.
- g) Switching withstand.
- h) Colour appearance and colour rendering index.
- i) Light distribution (NEW).
- j) Power factor (real and apparent).
- k) Harmonics.
- l) Interference with infra-red devices (NEW).
- m) Mercury content.

This Standard also identifies information to be included in the Test report. See Appendix D.

Safety and electromagnetic compatibility (EMC) requirements are additional requirements that are not covered in this Standard.

2 Normative references

The following referenced documents are indispensable for the application of this document. For dated references, only the edition cited applies. For undated references, the latest edition of the referenced document (including any amendments) applies.

CIE 13.3, *Method of measuring and specifying colour rendering of light sources*

CIE 63, *The spectroradiometric measurement of light sources*

CIE 69, *Methods of characterizing illuminance meters and luminance meters: Performance, characteristics and specifications*

CIE 84, *Measurement of luminous flux*

CIE 121, *The photometry and goniophotometry of luminaires*

IEC 60038, *IEC Standard Voltages*

3 Terms, definitions, symbols and dimensions

3.1 Terms and definitions

For the purposes of this document, the following definitions apply.

3.1.1

Average life (life to 50% failures)

The length of time during which, 50% of the lamps in a batch cease to operate.

3.1.2

Burn-in time

Use EN 13013

3.1.3

Colour

The colour characteristics of a lamp are defined by the **colour appearance** and the **colour rendition**.

- a) The actual colour of the lamp is called colour appearance and is defined in terms of the spectral tristimulus values (colour co-ordinates) according to the recommendations of the CIE.
- b) The spectral characteristics of the light emitted by the lamp have an effect on the appearance of the objects it illuminates; this effect is called colour rendition.

3.1.4

Colour Rendering Index (CRI)

The Colour Rendering Index (CRI) is a relative measure of the shift in surface colour of an object when lit by a particular lamp, compared with how the object would appear under a reference light source.

CRI is a numerical representation that rates the 'colour rendering' ability of a light source in comparison with natural daylight, which has a CRI of 100.

3.1.5

Efficacy

Efficacy is the ratio of luminous flux of a lamp to the power dissipated in the lamp under the specified conditions of measurement. Symbol: F , units: lumens watts⁻¹. Efficacy is normally determined at a specified point in the lamp life.

3.1.6

First start stabilised values

The photometric characteristics of the lamp, as it attains stable values after 15 to 24 hours, since the lamp was first switched on.

3.1.7

Initial efficacy

Initial efficacy is the efficacy measured on a new lamp after 100 h of operation. Symbol: F_{100} , units: lumens watts⁻¹.

3.1.8

Initial values

The photometric and electrical characteristics of the lamp at the end of the 100 h of operation.

3.1.9**Lamp failure**

If the luminous flux of a lamp falls to < 50% of its initial value, then the “Lamp failure” is deemed to have occurred.

3.1.10**Lamp life (of an individual lamp)**

The time duration during which, a lamp unit operates until its failure as defined in 3.1.9. This does not include the time the lamp is off.

3.1.11**Lumen maintenance**

The ratio of luminous flux of a lamp at any instant to the initial luminous flux expressed as a percentage of the initial luminous flux.

3.1.12**Maintained efficacy**

Maintained efficacy is the efficacy measured at after a specified number of hours of operation. Symbol: FM, units: lumens watts⁻¹.

3.1.13**Rated average life (rated life to 50% failures)**

The time duration declared by the supplier as being the expected time at which 50% of a specified batch of lamps cease to operate.

3.1.14**Rated colour temperature (correlated colour temperature)**

The colour appearance as declared by the supplier, or the colour corresponding to the colour designation marked on the lamp.

3.1.15**Rated frequency**

The frequency marked on the lamp or declared as such by the supplier.

3.1.16**Rated voltage**

The voltage or voltage range marked on the lamp or declared as such by the supplier.

3.1.17**Rated wattage**

The wattage marked on the lamp or declared as such by the supplier.

3.1.18**Rated luminous flux**

The luminous flux marked on the lamp or declared as such by the supplier.

3.1.19**Rounding**

The numerical values that apply in this Standard, shall be rounded and recorded in accordance to AS 2706, unless stated otherwise.

3.1.20**Run-up time**

The time elapsed for the lamp to reach a specified proportion of its stabilised luminous flux after the supply voltage is switched on. For the purpose of this part of the standard, the proportion of first start stabilised luminous flux is measured at 60 seconds.

3.1.21**Self-ballasted compact fluorescent lamp**

A fluorescent light source unit provided with single lamp cap and integral components for starting, control and stable operation that cannot be dismantled without being permanently damaged. From here on referred to in this part of the standard as a “lamp”.

3.1.22**Stabilisation time**

The burn-in time of the lamp required to attain stable operating electrical and photometric characteristics.

3.1.23**Starting time**

The time elapsed since the supply voltage is switched on, for the lamp to start fully and remain lit. This is often defined by the time taken to achieve a specified proportion of its stabilised luminous flux. For the purpose of this part of the standard, the proportion of first start stabilised luminous flux is measured at 2 seconds.

3.1.24**Test voltage**

The voltage at which, tests are carried out.

3.1.25**Test frequency**

The frequency at which, tests are carried out.

3.1.26**Type**

Lamps that are, independent of the type of cap or base, but are identical in photometric and electrical characteristics.

4 General conditions for measurements**4.1 General**

Unless otherwise specified, measurements shall be made under the test conditions and with equipment conforming to **Clause 4**.

4.2 Air movement and temperature**4.2.1 Test room**

Measurements shall be taken in a room maintained at an ambient temperature of $(25 \pm 1)^\circ\text{C}$ unless otherwise specified in this part of the standard. Air movement shall be in accordance with Clause 4.3.2 of CIE 121-1996.

4.2.2 Ageing room

For lamp ageing, prior to lamp life and lumen maintenance tests, the ambient temperature shall be in the range of 15°C to 40°C . Some draught is allowed but vibration and shock should be minimised.

4.3 Supply**4.3.1 Test voltage and frequency**

The test and ageing voltage and frequency shall be the nominal voltage and the frequency of the country for which the measurement is being determined, as shown in ANNEX A.

4.4 Position of lamp

Unless otherwise stated for specific purposes, the lamps shall be mounted in a vertical base-up position and operated in free air for all tests including life tests.

4.5 Stabilization time

For all tests, excluding starting and run-up tests, the lamp shall not be considered stable until repeated measurements of the lamp cease to show a trend in a particular direction. Repeated measurements shall be taken for at least a period of 20 minutes after start up.

5 MEASUREMENT EQUIPMENT AND ACCURACY

5.1 Test supply

The test voltage shall be within +/-1% of the value specified in clause 3.2.3. The test frequency shall be within +/- 0.1% of the value specified in clause 3.2.3.

The total harmonic content in the supply voltage for the measurements, up to and including at least the 13th harmonic, shall not exceed 2% of the fundamental. The total harmonic content is determined by summation of the individual frequency r.m.s. voltages using the fundamental as 100%.

This shall be measured using a resistive load (e.g. an incandescent lamp) of approximately the same wattage as the lamp under test.

5.2 Ageing supply

The ageing voltage shall be within +/-3% of the value specified in clause 3.2.3. The ageing frequency shall be within +/- 0.1% of the value specified in clause 3.2.3.

The total harmonic content in the supply voltage for ageing, up to and including at least the 13th harmonic, shall not exceed 5% of the fundamental. The total harmonic content is determined by summation of the individual frequency r.m.s. voltages using the fundamental as 100%.

5.3 Power measurement

Measurements of power shall be made with a suitably calibrated wattmeter or power analyzer with an uncertainty of less than or equal to 0.8% at the 95% confidence level. The power measurement instrument shall have a resolution of:

- 0.01 W or better for power measurements of 10 W or less.
- 0.1 W or better for power measurements of greater than 10 W up to 100 W
- 1 W or better for power measurements of greater than 100 W.

NOTE: See Annex D and ISO Guide to the Expression of Uncertainty in Measurement for further details.

5.4 Luminous flux measurement

5.4.1 Measurement equipment for tests

These tests shall be made with a photometer head and an illuminance photometer, where the head has the following characteristics:

- Deviation of the relative spectral responsivity from the $V(\lambda)$ function shall be +/- 1%, or the error should be corrected to this value using CIE 69, Section 7.1.
- UV and IR response of less than 0.2%.
- Linearity error of less than 0.2%.

For the illuminance photometer, the effect of the display unit shall be less than 0.2%.

- **F₇(v)** Still under investigation

5.4.1.1 Integrating Sphere

An integrating sphere with a diameter at least ten times the largest dimension of the lamp will be required for starting and run up tests. The sphere can also be used to determine lamp efficacy. The internal surface of the sphere shall be coated with diffuse non-selective paint in accordance with CIE 84. The lampholder and supports should be as small as possible and preferably highly reflective. The sphere shall have a screen between the centrally located light source and the photometer head port.

5.4.1.2 Goniophotometer (Distribution Photometer)

This instrument for measuring the directional light distribution characteristic of sources is too slow for starting and run up tests but can be used to determine lamp efficacy. See CIE 121 Clause 5.1.2 for positioning of the lamp. Total luminous flux can be obtained by averaging readings at Russel angles or the use of zone factors but care should be taken of mechanical obstructions and creation of draughts.

5.4.1.3 Spectroradiometer

An instrument that separates the optical radiation into its spectral components usually using a monochromator. Accuracy should be better than +/- 0.2 nm over the visible spectrum.

5.5 Time measurement

Measurements of event time shall be made with an overall uncertainty of ± 0.05 % or better.

5.6 Mercury content measurement

Refer to. ANNEX B.

6 TEST PROCEDURES

See flow chart for sequence of tests, sample sizes and appropriate equipment from section 4.

6.1 Starting and Run-up Tests

The unused lamp, shall be set-up in accordance with section **2 and 3**, except for stabilisation time, and using equipment in accordance with Section 4 and as shown in Figure 1.

The starting and run-up tests shall be made before ageing. The test shall be conducted at 92% of the test voltage.

The lamp shall be switched on and test equipment triggered such that luminous flux is plotted against time.

High speed recording should be carried out around the Starting time, then around the Run-up time. This may require manual retriggering of the test equipment. Values are taken or stored and the equipment shall then be left running for at least 15 hours. Between 15 and 24 hours a further set of measurements shall be taken to give the First Start stabilised values. At the time of these measurements the lamp should no longer show a trend in a particular direction.

Following completion of the test, the achievement of Starting time and run-up time requirements may be determined in accordance with Appendix A.

NOTE: CIE 121 Clause 5.1.3.2 defines 15 Hours stabilisation time and the use of first time stabilised values, which allow the instruments to be used to collect relative values. Uncertainties can be determined using instrument linearity errors.

6.2 Low Temperature Start-up Test

Burnt in lamp

6 deg C cooling cabinet

Lamp to switch on (confirmed by visual inspection)

6.3 Initial Efficacy Test

The sample of lamps (refer flow chart for sample size) shall be set-up in accordance with section 3.

Luminous flux shall be measured using one of the methods in CIE Publication 84. The preferred method is to compare the lamp to an incandescent reference flux standard within an integrating sphere or upon a goniophotometer. Application of a colour correction factor is recommended. Luminous flux and input power should be recorded at the same time after stabilisation. Although a self-ballasted lamp often needs 15 hours to stabilise the first time, if care is taken to maintain its base-up position it can be considered as stabilised after 20 minutes after ageing for 100 hours. Stabilisation should be monitored by performing repeated measurements and ensuring that the values do not show a trend in any particular direction.

Drafting Note: Add set-up diagrams

6.4 Lumen Maintenance Test (maintained efficacy)

The sample of lamps that underwent initial efficacy tests shall be aged according to the cycle defined in clause 5.2 for the specified number of hours of operation. Unless specified elsewhere, the lumen maintenance test shall be undertaken after 2,000 hours of operation. Maintained efficacy shall then be calculated using the same procedure as 4.3 above.

Further lumen maintenance tests may be performed as required, in increments of approximately 1000 hours. One of these tests shall be performed at the manufacturer's claimed lamp life.

6.5 Lamp Life Test

The sample of lamps shall continue to age after the maintained efficacy test. The hours of operation shall be recorded for each lamp, until lamp failure as defined in 1.5.9. This is usually determined by inspection but in the case of doubt is determined by a separate lumen maintenance test.

Drafting note: include suggested sample sizes for tests in a separate section.

6.6 Switching Withstand Test

Burnt in lamp.

15 sec on, 4'45" off.

12,000 to 20,000 cycles (comments invited).

6.7 Tests for Colour Appearance and Rendering Index

The chromaticity co-ordinates (Correlated colour temperature) and colour rendering index (CRI) shall be determined after 100 hours burn-in. Table 2 below gives chromaticity co-

ordinates for standard lamp colours. The chromaticity co-ordinates shall be measured with a spectroradiometer in accordance with CIE 63:1984. Deviation in the chromaticity co-ordinates is defined by MacAdam ellipses in SDCM units (standard deviation of colour matching). The difference between the measured chromaticity co-ordinates and the rated values is determined (in SDCM units) by the following equation:

$$g11 \Delta x^2 + 2 g12 \Delta x \Delta y + g22 \Delta y^2 = SDCM / 5 \text{ squared}$$

Drafting Note: formula and wording require checking by Steven Dain

The value of 5 SDCM units from table 2 co-ordinates can be determined from the diagrams in ANNEX X.

From spectroradiometric measurements the colour rendering index should be determined in accordance with CIE 13.3—1995.

For the standardized chromaticity co-ordinates the following rated values x and y apply for the different lamp 'colours' (with the correlated colour temperatures T_c in kelvin given as extra information):

Drafting Note: intermediate values – use closest or look up by Steven Dain

TABLE 2

'Colour'	T_c	x	y
F 6500	6400	0,313	0,337
F 5000	5000	0,346	0,359
F 4000	4040	0,380	0,380
F 3500	3450	0,409	0,394
F 3000	2940	0,440	0,403
F 2700	2720	0,463	0,420

6.8 Light Distribution Test

Using a goniophotometer, the Nadir measurement shall be taken and enough values at 90 degrees from Nadir to determine an average of the 90 degree plane.

6.9 Power Factor Test

The lamp shall be set-up in accordance with section 2 and 3. The power factor shall be determined after 100 hours of normal operation. Real power factor shall be determined using an instrument which divides instantaneous real power by the instantaneous apparent power. Apparent power factor shall be determined by the cosine of the phase angle between voltage and current (fundamental frequency).

6.10 Test for Harmonics

Refer to appropriate part of IEC 61000

6.11 Test for Interference with Infra-red Devices

Under consideration

6.12 Mercury Content Test

Tests for mercury content of lamps shall be carried out on a separate sample of lamps in accordance ANNEX B.

7 Sample Sizes for Tests

8 Marking Requirements

Where a CFL is marked with an energy performance mark, the mark shall be as indicated in Appendix C.

NOTE: The energy performance mark is not a label providing information on the energy performance of the lamp to consumers.

9 TEST REPORT

See ANNEX C

ANNEX A (informative)

Typical Nominal Electricity Supply Voltages

TYPICAL NOMINAL ELECTRICITY SUPPLY DETAILS FOR SOME REGIONS

Country/Region	Nominal Voltage and Frequency *	Maximum allowable variation in electricity supply (%) *
Australia	230 V, 50 Hz	+ 10% / - 11%
New Zealand	230 V, 50 Hz	± 6%
China	220 V, 50 Hz	± 6%
Europe	230 V, 50 Hz	± 6%
Japan **	100 V, 50/60 Hz	TBA
North America	115 V, 60 Hz	TBA
UK	230 V, 50 Hz	+ 10%, - 11%

NOTES:

* Other country voltage in accordance to IEC 60038 is purely for information only.

** "50 Hz" is applicable for the Eastern part; "60 Hz" is applicable for the Western part respectively.

Annex B (normative)

Method for Determining the Mercury Content in lamps

A.1 General

A.1.1 Scope

This standard specifies a method of test to determine the quantity of mercury (Hg) present in any type of fluorescent lamp, excluding mercury present in the vapour state.

This test method specifies the procedures which can be used to determine accurately the mercury content of any type of fluorescent lamp in which mercury has been introduced as the carrying agent for the discharge between the electrodes.

The method involves the chemical digestion of the mercury contained within a lamp and the determination of that mercury content on a per lamp basis. This is achieved using a method of solubilisation of the entire mercury content contained within the tube using acidic digestion methods and the accurate determination of that mercury content using standard mercury solutions to determine that mercury content. This will allow comparison between the mercury content of different lamps and with internationally accepted standards set for lamp mercury content.

A.2 Definitions

For the purpose of the standard the following definitions apply.

A.2.1

Fluorescent Lamp

A discharge lamp of the low pressure type, in which most of the light is emitted by one of several layers of phosphors excited by the ultra-violet radiation from the discharge from the electrodes.

A.2.2

Double capped fluorescent lamp

Fluorescent lamp having two separate caps and mostly of tubular form and linear shape.

A.2.3

Single capped fluorescent lamp

Fluorescent lamp with a single type cap but with the discharge tube bent or formed into a spiral or convoluted tube. These may or may not contain Mercury as amalgams.

A.2.4

Discharge electrodes

Discharge electrodes are located in the lamp caps and may be of simple tungsten wire design, or may comprise a grid or container in which a mercury amalgam is present.

A.2.5

Mercury and amalgams

Mercury in fluorescent lamps is generally free mercury or mercury vapour under discharge which provides the conducting agent between the electrodes. Mercury in fluorescent lamps may exist in three possible states as followed:

- 1) Vapour in a lamp
- 2) Liquid metal or in an oxidised state.
- 3) An amalgam of mercury with another metal such as Titanium (Ti), or Bismuth (Bi).

This test method determines the total amount of mercury present as either liquid metal, or oxidised state, or in an amalgam. Mercury in the vapour state is not determined but represents only a very minor fraction of any mercury and can for all practical purposes be ignored in the determination.

A.2.6

Lamp samples

A minimum of three samples of the same model lamp, selected from the same manufacturer's batch, should be used to determine the mercury content of the lamp model.

In order to select the correct digestion procedure(s), it must be determined prior to the start of the analysis whether the lamp contains a mercury amalgam.

A.2.7

Measurement equipment

The equipment used for preparing and measuring the sample for determination of mercury.

A.2.8

ICP-OES

An inductively coupled plasma optical emission spectrophotometer used for the determination and calculation of the mercury content of the final sample.

A.3 General Test Procedure

Test conditions are set up to determine the mercury content in a series of at least three lamps of the same type by breaking the lamp itself under controlled and captive conditions (Method 1) or breaking the vacuum seal of the lamp to allow the interior contents to be accessed (Method 2).

The method and procedures described in this document are to take place in a controlled environment of a chemical laboratory. All safety precautions shall be used for the protection of the laboratory analyst from the lamps, the destruction of the lamps and the mercury and any other phosphor content of the lamps. The procedures must be carried out in the safety of a chemical laboratory equipped for the handling of hot acids, mercury and glass materials using the appropriate fume cupboards and other hazard protection equipment. All materials are to be disposed of using proper disposal procedures for these types of wastes including mercury wastes.

The total mercury in the lamp is determined by dissolving the entire mercury content in any of its forms in a suitable acid mixture to ensure all mercury is entirely dissolved from the interior contents of the lamp.

The method then measures the mercury in the dissolved acid mixture taking account of the actual volume of acid used in the determination and measurement of the mercury in the acid samples using the methods of inductively coupled plasma with optical emission spectra measured in the spectrophotometer (ICP-OES). The mercury readings from the emission spectra are then calculated against known prepared mercury standard solutions to calculate the actual mercury content for each lamp or batch of lamps.

A.4 Measurement Equipment

A.4.1 Preparation Equipment Required – Method 1

- a) Pliers and sharp knife
- b) Beakers, volumetric flasks, measuring cylinders
- c) Disposable 3ml plastic transfer pipettes
- d) Putty or plasticine or similar

- e) Automatic pipettors to dispense specific volumes and disposable tips
- f) 0.45 micron filters suitable for acid solutions of up to 200 ml.
- g) Glass scoring file, heating wire and heater, hammer
- h) Electric hot plate suitable for heating the acid in the bulb itself, or beaker
- i) Safety gloves (teflon type)
- j) Acid protective equipment, gloves and safety glasses, lab coat.

A.4.2 Reagents- Method 1

- a) Nitric acid, HNO₃, concentrated, 70%
- b) Water: High Grade Distilled water or Milli Q.
- c) Dilute Nitric acid (1+1): Equal volumes of nitric acid, 70% and water. The nitric acid shall be added to the water and mixed. Caution: A high amount of heat transfer occurs during mixing. Always add acid to water.
- d) Standard solution of mercury salts ie 1000mg per litre mercuric nitrate purchased from an appropriate supplier.
- e) Diluted standard solutions, standard mercury solution (2.1.1.4) diluted in deionised water. Mercury standard solution should be diluted on the day of measurement.

A.4.3 Additional equipment for Method 2

- a) Round-bottomed flask of type suitable for reflux procedures, which includes one glass stoppered side arm
- b) Reflux condenser
- c) Electric heating mantle for round-bottomed flask for refluxing

A.4.4 Additional reagents for Method 2

- a) Hydrochloric acid, HCl, concentrated, 37%
- b) Aqua regia: concentrated nitric acid is mixed with three times the volume of concentrated hydrochloric acid. Use caution when making this solution.
- c) Sulphuric acid, H₂SO₄, 98%
- d) Sulphuric acid (1+1): Equal volumes of sulphuric acid and water. Caution: A high amount of heat transfer occurs during mixing. Always add acid to water.

NOTE: All chemicals must be high quality analytical reagent (AR) grade

A.4.5 Instruments

Inductively Coupled Plasma -Optical Emission Spectrometer (ICP-OES):

The instrument which gives light emission intensity with suitable sensitivity and stability in the directed measurement and concentration range for detection of the mercury emission spectra. Refer to the specific operating manuals for such instruments. Suitable instruments are manufactured by a number of manufacturers and are available in suitably equipped inorganic chemistry laboratories.

Gas:

High quality pure, inert Argon gas, is used as the principle carrying gas for the plasma torch of the instrument.

An example of the principle of an ICP-OES is shown in Fig. 1.

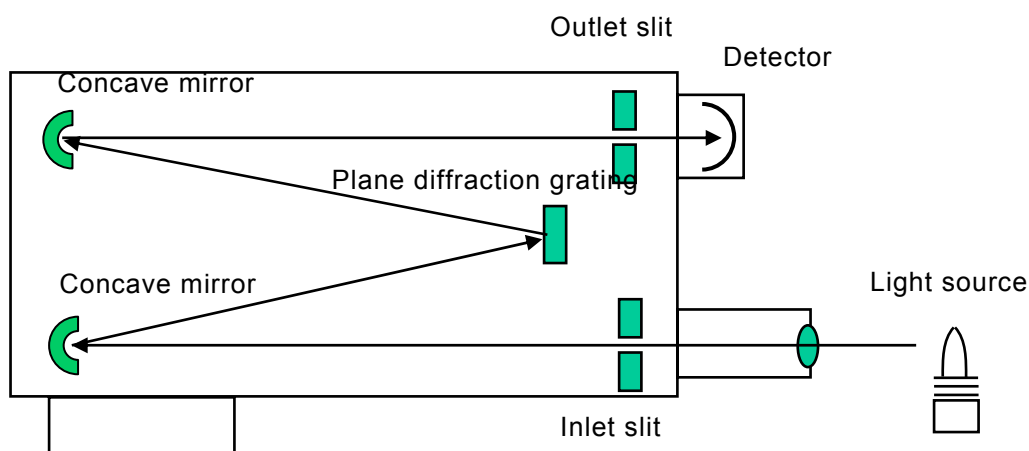

Fig.1 Spectrophotometry part using sequential type spectroscope (an example)

A.5 Test Setup

A.5.1 Lamps

The test of lamps is setup by obtaining a selection of lamps that are required to be tested. These should be clearly labelled as samples for test and require a minimum of three lamps of identical type and markings from the same manufacturing run. Groups or batches of lamps separately labelled may be tested in parallel provided all samples are separately coded and recorded throughout the determination procedure.

A.5.2 Laboratory

A suitably equipped inorganic chemical laboratory with separate wet chemistry preparation areas is required. Mercury preparations and acids shall be handled in an acid-suitable, fume cupboard. Preparation areas and safety equipment maintained according to relevant standards.

Lamps shall not be broken or treated in a laboratory where other mercury determinations are being made. All lamp handling and acid preparation procedures must be carried out in a separate preparation laboratory to the measuring equipment, and equipped with a suitable fume cupboard.

Proper procedures for disposal of all materials, glass, metal and acids shall be available at the laboratory location.

A.5.3 Sample setup

A.5.3.1 Labelling

All lamps to be tested shall be labelled and all manufacturer's marks recorded onto separate test sheets clearly identifying each lamp sample.

All beakers, flasks, plastic containers or bags used for holding acid digestions for determination shall be separately labelled and recorded on test sheets.

A.5.3.2 Acids

All acids required, dilutions or mixtures of acids shall be prepared in the fume cupboard and separately labelled and recorded.

A.5.3.3 Standard solutions

All standard solutions required for measurement and determination of concentration shall be separately prepared and recorded in standards test sheet records.

A.5.3.4 Preparation equipment

All minor equipment, glassware and plastic equipment and heating equipment shall be collected, prepared and tested to ensure its reliability, accuracy and functionality.

All measuring equipment used, volumetric flasks, pipettes, dilution equipment, pipettors shall be checked to ensure that they are delivering correct volumes and amounts as required in the procedure.

A.5.4 Measuring equipment setup

The ICP-OES used for measuring the concentration of mercury in the final sample solutions shall be separately maintained according to the manufacturer's specifications. The daily maintenance checks and records of the instrument's performance in measuring the various elements will normally be a routine procedure of the laboratory measuring the elements. These routine laboratory quality procedures are to be followed and the instrument checked for accuracy and reliability of measurement for the mercury emission spectra using the standard procedures in place for the ICP-OES instrument.

Appropriate procedures for the automatic sampling equipment and argon gas supplies are also to be checked according to routine daily laboratory procedures.

A.6 Test Procedures

Two test methods are described below:

Method A or Method B may be used for fluorescent lamps not containing mercury in amalgam form.

Method B shall be for fluorescent lamps containing mercury in amalgam form.

A.6.1 Method A: Mercury decomposition in a lamp bulb not containing amalgams

- a) The metal caps of the fluorescent tubes shall be removed. This may be done by twisting off the caps with pliers while holding the tube wrapped in paper towel to prevent glass injury. This will break the cement holding the caps and the wires.
- b) At one end of the tube, break the small central inner glass tube used to evacuate the tube. This may be done using pliers.
- c) Introduce the required amount of diluted nitric acid (see 2.1.2.3) into the lamp using a 3ml plastic transfer pipette. Acid shall be introduced in 3ml lots while rotating the tube so that the phosphor is washed off the inside of the tube.
- d) Once the required amount of acid is introduced, the broken end of the evacuation tube shall be plugged with a small amount of putty, plasticine or similar, and the tube inverted several times to wash the insides of the tube and filaments so that all phosphor is removed.
- e) The lamp shall then be placed vertically into the preheated hot plate designed for the purpose and maintained at between 80°C to 100°C for 50 minutes. The tube shall be

inverted every 10 to 15 minutes to ensure that the filament parts at the top end of the lamp are washed in hot nitric acid.

- f) Following (e), hold the lamp over a beaker and again carefully break the evacuation tube at the other bottom end of the tube with pliers and allow the solution to run into a beaker.
- g) Introduce another 20 ml of diluted nitric acid into the lamp through the upper evacuation tube while holding over the beaker, rotating the tube to ensure all the inside is washed. Hold the tube horizontally and rotate carefully then allow the solution to run into the beaker. Wash the tube with a further 20 ml of water ensuring that all parts of the tube is washed thoroughly. Collect all washes. The final volume should be less than 200 ml.
- h) The final solution shall be filtered through a 0.45 micron filter into a volumetric flask. Water shall be added to make up a total volume of 200 ml.
- i) This solution is then diluted as required and appropriate samples analysed using ICP-OES. The analysis must include a minimum of three samples of any light bulb batch as well as the blanks and standards.

A.6.2 Method B: Mercury decomposition in a lamp bulb containing amalgams.

- a) Remove the plastic base and base cement completely with a knife, or pliers from the bulb.
- b) Score the bulb with an appropriate glass scoring file on or near the end of the tube with a file.
- c) Heat a glass rod or Nickel/Chromium wire to red heat and touch the score line to crack the bulb and allow the lamp bulb leak to atmospheric pressure.
- d) Take out the amalgams from the inside of the tube and dissolve them in accordance with the method 4.2 given below.
- e) Wet all of inside of the bulb with water in order to prevent losing mercury contained in the dry phosphor coating when the bulb is broken into pieces. Collect the water in a beaker.
- f) Put the bulb into a thick plastic bag and break it by hitting the bulb from outside the plastic bag with a hammer or heavy object (see figure 2), or break the bulb inside a beaker, jar or similar container depending on the size of the bulb with pincers or pliers. (In order to prevent the plastic bag from being cut, pincers or pliers can be used to break up into smaller pieces).

Note: An alternative method that can be used is to use a suitable glass or plastic flask or other lidded container in which to break the pieces, then smashing the contents further with a large porcelain or glass ball (toy marble).

- g) In either case, with a plastic bag or flask it is intended to minimise injury to the operator as well as contain all pieces of glass. Ensure complete digestion of all the contents.
- h) Tip all the pieces from the bag into a beaker and rinse inside the plastic bag or container with known amount of water.
- i) Make up the volume of solution in the beaker containing water with concentrated nitric acid to be a 1+1 concentration (about 30 ml). Stir or wash the pieces around the container with a glass rod until no more phosphor comes off from the pieces of glass. Heat the beaker on a hot plate and keep at about 80 °C for 50 minutes.
- j) Cool the solution to room temperature. Filter through a 0.45 micron filter. Transfer the filtrate and filter washings into a volumetric flask and water added to make up to an appropriate volume⁽¹⁾⁽²⁾⁽³⁾.

Notes

⁽¹⁾This sample solution can be stored for a week, however diluted test solutions should be measured on the same day.

⁽²⁾The amount of diluent depends on the size and shape of the lamp, since the mercury content of the lamp tube with the amalgam removed from the lamp may be very small, the amount of diluent should be small as possible.

⁽³⁾ In the case of a lamp containing an amalgam do not make up to final volume until the solution from **Section 4.2** is added to the flask.

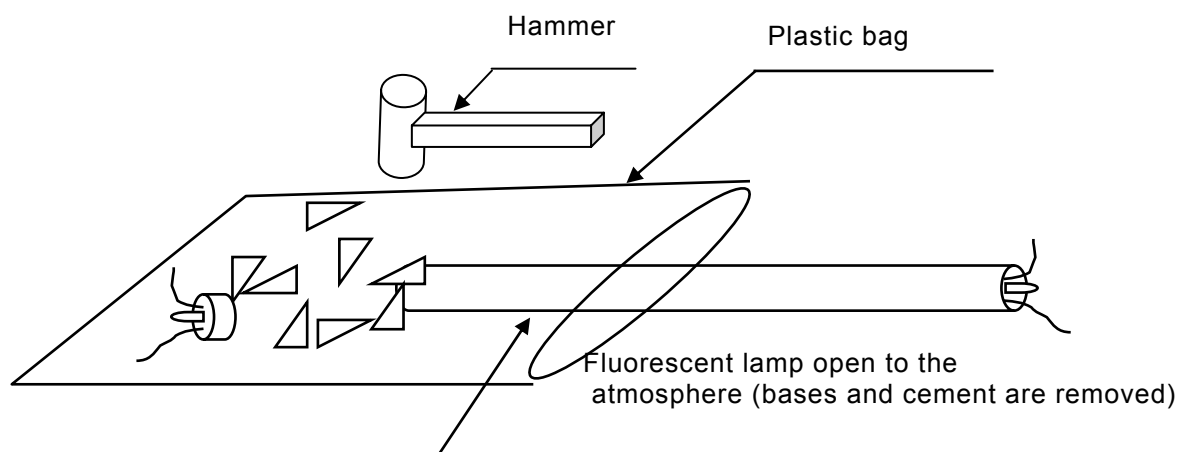

Fig. 2 Method of lamp destruction using the plastic bag method.

A.6.2.1 Decomposition of mercury amalgams: Titanium amalgam

An example of a titanium amalgam contained in a fluorescent lamp is shown in Fig.3

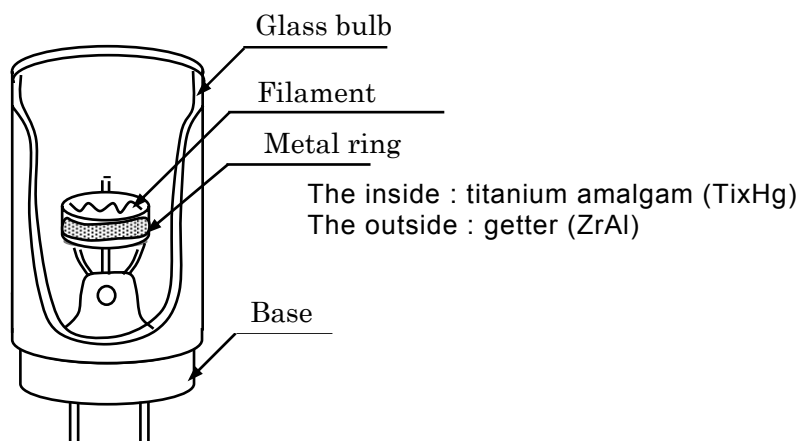

Fig.3 Example of titanium amalgam in a fluorescent lamp electrode

- a) Take amalgam with metal ring from inside of a lamp after using procedure described in section 4.1.2.1-4 and put it in a round-bottomed flask.
- b) Connect a reflux condenser to the round-bottomed flask, place into a heating mantle which is placed in a fume cupboard. Ensure that the cooling water is flowing through the condenser.

- c) Add 10ml of dilute sulphuric acid (1+1) through the side arm and heat gently for about 30 minutes.
- d) Add 5 ml of dilute nitric acid (1+1) through the side arm and heat until white fumes are observed.
- e) Add 5 ml of dilute nitric acid (1+1) through the side arm and heat until any salts which have formed have completely dissolved.
- f) Cool the contents and proceed to filter and make up in a volumetric flask to a known volume as previously described. Record all final volumes on the test sheets.

If the amalgam is within a bulb, add this filtered solution to that of the solution in the volumetric flask from 4.1.2.9.

A.6.2.2 For other types of amalgam pellet and amalgam mesh containing lamps

An example of amalgam pellets and amalgam mesh contained in a fluorescent lamp are shown in Fig.4

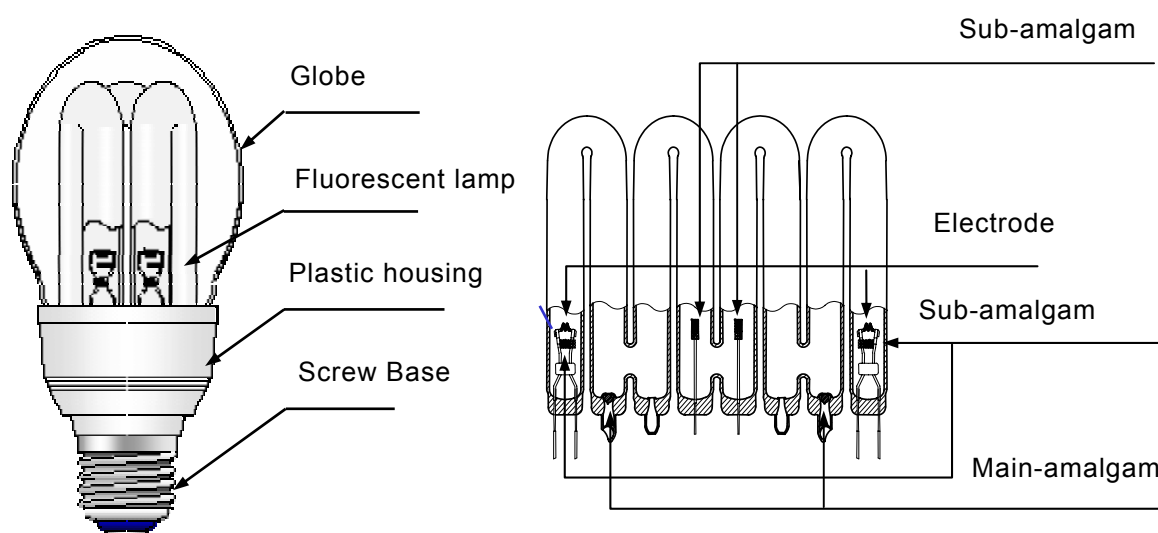

Fig.4 Examples of amalgam pellets and amalgam mesh contained in fluorescent lamps.

- a) Remove the fluorescent lamp carefully from the plastic housing using a knife or pliers as appropriate.
- b) Let the fluorescent lamp leak slowly to atmosphere using procedure above (4.1.2), break open the tube and take out the amalgam pellet and the amalgam mesh from the fluorescent lamp.
- c) Put them into a beaker and add 10 ml of aqua regia.
- d) Heat for 90 minutes at 80°C.
- e) After cooling the sample solution to room temperature, filter the solution through a 0.45 micron filter and transferred to an appropriate volumetric flask. Rinse the filter with water thoroughly and add water to marked line of a volumetric flask to make up the test solution (see note).

Note:

When the solution contains Bismuth, deposition of Bismuth may occur in accordance with a drop in acidity. Ensure aqua regia concentration exceeds 10% of the total volume within the volumetric flask.

A.6.3 Samples for measurement.

All samples are then transferred to 15 ml plastic tubes in an appropriate sample volume to the automated sampler on the ICP-OES. The volumes are recorded and appropriate blanks, duplicates and standard dilutions added to the sampling rack.

A.7 Measurement

A.7.1 Inductively Coupled Plasma-Optical Emission Spectrophotometry

A.7.1.1 General

After dissolving mercury from the lamp and/or amalgams by using nitric acid or other acids, the insoluble components are removed by filtering and the filtered solution made up to an appropriate volume. The appropriately diluted sample solutions are sprayed into plasma on the ICP-OES and the intensity of optical emission of mercury is measured and the mercury concentration for the whole lamp determined using procedures developed for the instrument.

A.7.1.2 Instruments

- a) ICP-OES - The instrument that gives light emission intensity with suitable sensitivity and stability in the directed measurement and concentration range. This type of instrument is made by several manufacturers.
- b) Gas: pure inert Argon gas as carrier gas into the plasma.

Note:

See Figure 1 above for principle of ICP-OES.

A.7.1.3 Setting of measuring conditions

There is a possibility of memory effect when low mercury concentration sample is measured after a high mercury concentration sample. To avoid the memory effect, ensure that the rinse time is adequate. This is confirmed by analysing known standard solutions and determining that the concentration assayed is correct.

Note:

Plasma output, photometric height, flow rate of carrier gas, etc. are varied to set for optimum conditions. These are determined by the trained instrument operator according to normal measurement conditions for the instrument at that time.

A.7.1.4 Quantitative analysis from the ICP-OES

- a) Select the mercury analytical line at wavelength of 194.2 nanometres (nm) for measuring light emission intensity. When spectral interference is found not to exist, the analytical line at 253.7nm or the other spectral line may be used.
- b) As any coexisting elements other than mercury in the sample solution could have spectral interference on the mercury analytical line, a mercury spectral line without spectral interference should be selected by scanning around the mercury analytical line with spraying sample solution into the plasma⁽¹⁾.
- c) To avoid any effects of the phosphor in the matrix, a standard addition method should be used⁽²⁾. At least four solutions are sampled by an equal amount from the test solution to prepare one kind of solution wherein the mercury element is not added and at least three kinds of solutions wherein the mercury element is added respectively at different concentrations.
- d) The solutions are sprayed into the plasma and the intensity of atomic emission of mercury is measured. The relation curve between the light emission intensity of the mercury element in the test solution is obtained from the intercept on the axis of abscissa (concentration).

Calculate the amount of mercury in the florescent lamp with the following formula:

$$W=A \times C \times V / 1000$$

Where, W : amount of mercury in fluorescent lamp (mg)
 A : dilution rate
 C : mercury concentration of test solution ($\mu\text{g Hg/ml}$)
 V : amount of test solution (ml)

Notes

(1) As the line spectrum and continuous spectrum by a plasma composing component and a coexisting element are occasionally superimposed with each other for the analytical line as spectral interference, it is recommended that an analytical line with no spectral interference should be used. When spectral interference exists, the degree of the interference calculated as the concentration of mercury should be less than 1/100 of the concentration of mercury of the test solution by using a synthetic matrix solution.

(2) This method can be applied only to the case of no spectral interference, or where the background and the spectral interference are regularly corrected and the calibration line between the light emission intensity and the concentration remains linear in the low concentration area or area required for measurement (see Figure 5)

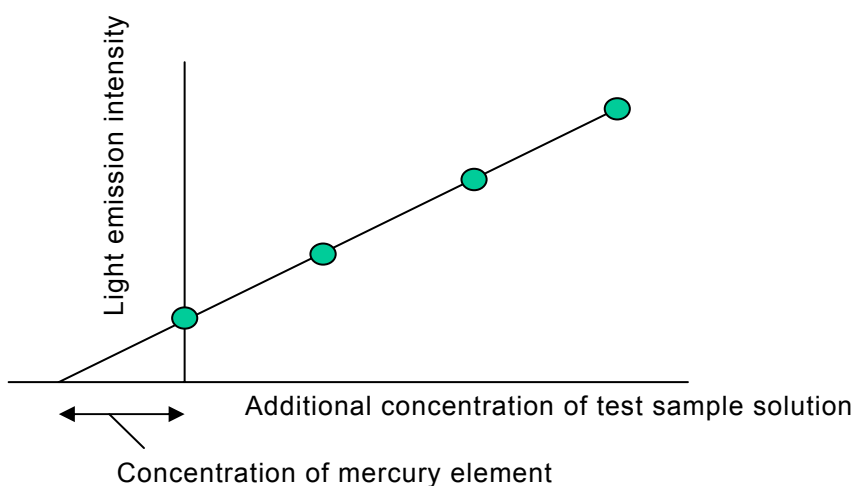

Fig. 5 Method for obtaining concentration by standard additional method

A.8 Reporting

All results from the measurement of solutions and all calculations should be recorded onto test sheets. The results are determined for the milligram amounts of mercury per lamp as an average of the three lamps used to determine the concentration for each particular type of lamp. All results should be recorded on a suitable report indicating the results expressed as milligrams mercury per lamp and also contain the quality report determination of the results of any blanks or standards measured in the same determination. Results of reports and calculations should be checked by a second chemist.

A.8.1 Measurement uncertainty.

Ideally the three determinations of mercury per lamp should show good agreement with a measurement uncertainty of <10%. The standard deviation for the measurement can be determined from the measurements where there is good agreement in the three results. If there is not good agreement, the measurement uncertainty will be large and this may require that more than three lamps of the same type(eg 10 lamps) be tested to get a better standard deviation measure. Alternatively, poor agreement of three mercury results with the same type of lamp from the same manufactured batch may indicate uneven injection of Mercury into each lamp and poor manufacturing practice.

ANNEX C

Energy Performance Mark

(Normative)

A.9 REQUIREMENT

When a compact fluorescent lamp (CFL) has an energy performance mark, the lamp shall be clearly and permanently marked with a numeral from the sequence I to X, indicating the energy performance of the CFL.

A CFL shall be marked with the appropriate numeral when it meets, or exceeds, the efficiency requirements associated with that numeral at all voltage and frequency values it is designed to operate at. The associated requirements for each numeral are shown in Table A1.

TABLE A1
ENERGY PERFORMANCE REQUIREMENTS FOR EACH NUMERAL

Mark	Efficiency
I	Used if it does not meet any of the following criteria
II	t.b.a
III	t.b.a
IV	t.b.a
V	t.b.a
VI	t.b.a
VII – X	Reserved for future use

A1 DESIGN OF THE ENERGY PERFORMANCE MARK

The characteristics of the mark shall conform to the following description:

Format: Roman numeral: I, II, III, IV, V, VI, VII, VIII, IX or X.

Numerals VI to X are reserved for future use.

Font: Times Roman preferred, but other plain serif fonts are acceptable

Colour: Text to contrast with the background colour.

Placement: On the CFL, with the exact location to be at the discretion of the manufacturer.

The mark shall be legible and indelible

An example of the mark is shown in Figure A1.

NOTE: The text 'Efficiency Level' may be omitted.

FIGURE A1 EXAMPLE OF NUMERAL INDICATING EFFICIENCY



APPENDIX C

Test Report (informative)

(Drafting Note: should this be in appendix D)

The following information shall be recorded in the test report:

1.1 Appliance (equipment) details:

- (a) brand, model, type, and serial number.
- (b) product description, *as appropriate*
- (c) rated voltage(s) and frequency(frequencies)
- (d) details of manufacturer marked on the product (if any)

1.2 Test Parameters

- (a) ambient temperature (°C).
- (b) test voltage(s) (V) and frequency (frequencies) (Hz).
- (c) total harmonic distortion of the electricity supply system
- (d) information and documentation on the instrumentation, set-up and circuits used for electrical testing.

1.3 Measured data

To be added

1.4 Test and laboratory details

- (a) test report number/reference
 - (b) date of test
 - (c) laboratory name and address
 - (d) test officer(s)
-