

## SELF-BALLASTED COMPACT FLUORESCENT LAMPS – METHODS FOR MEASURING THE PERFORMANCE

### FOREWORD

At the Right Light 6 conference in Shanghai in May 2005, Government and Industry representatives agreed to work towards the harmonisation of test methods and performance requirements for self-ballasted compact fluorescent lamps over a 2 year period.

A comparison of existing test methods used by a number of countries in APEC (the comparison is also believed to be valid worldwide) has clearly shown that for many performance criteria these test methods are very similar and there is great potential for harmonisation based around the existing IEC protocol. However, discussions with a variety of test laboratories demonstrate that the existing test methods require considerable interpretation and this may also introduce variations in results, depending upon the assumptions made by individual laboratories. As a consequence, there is a need not only for a single test method, but one which is sufficiently clear and robust that it can be easily followed, and the results replicated by different laboratories.

In addition, the existing test methods do not all specify the full range of tests relating to the performance criteria of most CFL programs. Having all potential tests contained within the single test method will also clarify the requirements for manufacturers and laboratories, and improve the potential for products to conform to programme requirements.

This document is a draft of a new Test Method for electronic self-ballasted CFLs and is largely based on the existing test methods, such as IEC 60969. However unlike 60969 it contains no performance requirements and only describes relevant test methodologies. It has drawn on work done by the Joint Standards Australia/Standards New Zealand Technical Committee EL-041-08, and by the NLTC in Beijing.

It is envisaged that the proposed set of performance requirements will be included in a separate document, at a later stage.

Comments should be sent to the project facilitator Mr **Stuart Jeffcott** at:  
[stuart@jeffcott.fsworld.co.uk](mailto:stuart@jeffcott.fsworld.co.uk))

Comprehensive details of the International CFL Harmonisation Initiative can be found at:

<http://www.apec-esis.org/cfl>

Stuart Jeffcott

Email: [stuart@jeffcott.fsworld.co.uk](mailto:stuart@jeffcott.fsworld.co.uk)

## CONTENTS

1 Scope.....	4
2 Normative references.....	4
3 Terms and definitions.....	5
3.1 Average lamp life.....	5
3.2 Equipment Under Test (EUT).....	5
3.3 Hours of operation.....	5
3.4 Lamp failure.....	5
3.5 Lamp life (of an individual lamp).....	5
3.6 Luminous efficacy.....	5
3.7 Initial values.....	5
3.8 Light distribution ratio.....	5
3.9 Maintained efficacy.....	5
3.10 Nadir.....	5
3.11 New Lamp.....	5
3.12 Power factor.....	5
3.13 Premature Lamp Failure.....	6
3.14 Rated value.....	6
3.15 Rounding.....	6
3.16 Run-up time.....	6
3.17 Self-ballasted compact fluorescent lamp.....	6
3.18 Starting temperature (Low temperature Starting time test).....	6
3.19 Starting time.....	6
3.20 Test frequency.....	6
3.21 Test voltage.....	6
4 General conditions for measurement of photometric and electrical characteristics.....	7
4.1 General.....	7
4.2 Air movement and temperature.....	7
4.3 Supply.....	7
4.4 Position of lamp.....	7
4.5 Stabilization time.....	7
4.6 Lamp Aging.....	7
5 Measurement Equipment and Accuracy.....	8
5.1 Test supply.....	8
5.2 Ageing supply.....	8
5.3 Power measurement.....	8
5.4 Luminous flux measurement.....	8
5.5 Time measurement.....	9
5.6 Mercury content measurement.....	9
6 Test Procedures.....	10
6.1 Starting Time Test.....	10
6.2 Run-up Test.....	11
6.3 Low Temperature Starting Time Test.....	12
6.4 Initial Luminous Flux Test.....	13
6.5 Initial Efficacy Test.....	16
6.6 Lumen Maintenance and Maintained Efficacy Tests.....	16
6.7 Lamp Life Test.....	16
6.8 Switching Withstand Test.....	17
6.9 Test for Colour Appearance and Rendering Index.....	17
6.10 Light Distribution Test.....	17
6.11 Power Factor Test.....	17
6.12 Test for Electromagnetic Compatibility (EMC).....	17
6.13 Mercury Content Test.....	17

7 Sample Sizes for Tests .....	18
8 TEST REPORT .....	18
Annex A Method for Determining the Mercury Content in Lamps (Normative) .....	19
Annex B Performance Marking (Normative) .....	29
Annex C Test Report (informative) .....	31

## **SELF-BALLASTED COMPACT FLUORESCENT LAMPS – METHODS FOR MEASURING THE PERFORMANCE**

### **1 Scope**

This International Standard specifies the test methods and conditions required for electronic self-ballasted, compact fluorescent lamps (CFLs), with integrated means for starting, controlling and stable operation.

This Standard is applicable for self-ballasted CFLs of all voltages and wattages irrespective of the type of lamp cap. This standard excludes cold cathode and non-general purpose lighting CFLs.

This Standard specifies test methods for the following:

- Efficacy.
- Starting time.
- Low temperature starting.
- Run-up time.
- Lumen maintenance.
- Lamp life (average).
- Premature lamp failure.
- Switching withstand.
- Colour appearance and colour rendering index.
- Light distribution.
- Power factor.
- EMC (incl Harmonics).
- Mercury content.

This Standard also identifies information to be included in the Test report. See Appendix C.

Safety requirements are additional requirements that are not covered in this Standard.

### **2 Normative references**

The following referenced documents are indispensable for the application of this document. For dated references, only the edition cited applies. For undated references, the latest edition of the referenced document (including any amendments) applies.

- CIE 13.3, Method of measuring and specifying colour rendering of light sources
- CIE 63, The spectroradiometric measurement of light sources
- CIE 69, Methods of characterizing illuminance meters and luminance meters:  
Performance, characteristics and specifications
- CIE 84, Measurement of luminous flux
- CIE 121, The photometry and goniophotometry of luminaires
- IEC 60050(845), International Electrotechnical Vocabulary
- IEC 60410, .....

### 3 Terms and definitions

For the purposes of this document, the following definitions apply.

For definitions relating to lighting, see IEC 60050(845).

#### 3.1 Average lamp life

The length of time in hours at which 50 percent of the sample of lamps undergoing the lamp lifetime test fail.

#### 3.2 Equipment Under Test (EUT)

The equipment under test, in this case a compact fluorescent lamp.

#### 3.3 Hours of operation

The number of hours of operation is the time in hours when the lamp is illuminated. Note that this **excludes** any period when the lamp is switched off.

#### 3.4 Lamp failure

If the luminous flux of a lamp falls to <50% of its initial value, or fails to give continuous illumination, then “Lamp failure” is deemed to have occurred, ie. the lamp shall be deemed to have reached the end of its life.

#### 3.5 Lamp life (of an individual lamp)

The hours of operation from first lamp illumination to lamp failure.

#### 3.6 Luminous efficacy

Quotient of the luminous flux emitted by the power consumed by the source. Unit:  $\text{lm} \cdot \text{W}^{-1}$

#### 3.7 Initial values

The photometric and electrical characteristics of a new lamp at the end of the 100 hour aging period.

#### 3.8 Light distribution ratio

The quotient of light intensity at Nadir, to the average of light intensities at 90 degrees to Nadir, when the lamp is mounted in a vertical base-up position.

#### 3.9 Maintained efficacy

The luminous efficacy measured after a specified number of hours of operation. Symbol:  $F_M$ , units:  $\text{lumens watts}^{-1}$ .

#### 3.10 Nadir

The angle pointing directly downward from the lamp or luminaire, or  $0^\circ$ .

#### 3.11 New Lamp

A lamp which has not been illuminated since packaged by the lamp supplier.

#### 3.12 Power factor

Power Factor is a measure of how effectively the lamp converts the incoming electric current into useable power. The true power factor is the ratio of the real (or active) power ( $P$ ) consumed in watts to the apparent power ( $S$ ), drawn in volt-amperes. Unit: no unit.

$$pf = P/S$$

### **3.13 Premature Lamp Failure**

Premature Lamp Failure is a lamp which fails before 1,000 hours of operation.

### **3.14 Rated value**

The values marked on the lamp or declared by the manufacturer or supplier.

### **3.15 Rounding**

The numerical values that apply in this Standard, shall be rounded and recorded in accordance to IEC XXX , unless stated otherwise.

*Drafting note: Reference to be added.*

### **3.16 Run-up time**

The period in minutes from when the supply voltage to the lamp is switched on, to the point at which the lamp reaches 80% of its final luminous flux (final luminous flux is defined as the point when variation in luminous flux is less than 2% per minute).

If the final luminous flux has not been reached within twenty minutes, Run-up time will be the period in minutes from when the supply voltage to the lamp is switched on, to the point where the lamp reaches 80% of the luminous output of the lamp after 20 minutes of test.

### **3.17 Self-ballasted compact fluorescent lamp**

A lamp unit which cannot be dismantled without being permanently damaged, provided with a single lamp cap and incorporating a light source and any additional elements necessary for starting and for stable operation of the light source. Referred to in this part of the standard as a "lamp" or EUT.

### **3.18 Starting temperature (Low temperature Starting time test)**

The ambient temperature surrounding the lamp used in the Low Temperature Starting time test.

### **3.19 Starting time**

The period in seconds elapsed from when the supply voltage to the lamp is switched on, to when the lamp reaches a state of constant illumination.

### **3.20 Test frequency**

The frequency at which tests are carried out.

### **3.21 Test voltage**

The voltage at which tests are carried out.

## **4 General conditions for measurement of photometric and electrical characteristics**

### **4.1 General**

Unless otherwise specified, measurements shall be made under the test conditions and with equipment conforming to Section 4.

### **4.2 Air movement and temperature**

#### **4.2.1 Test room**

Measurements shall be taken in a room maintained at an ambient temperature of  $(25 \pm 1)^\circ\text{C}$  and humidity of  $\leq 65\%$  unless otherwise specified in this part of the standard. Air movement shall be in accordance with Clause 4.3.2 of CIE 121-1996.

Lamps designed to operate in high ambient temperatures may be tested under the conditions for which they were designed.

#### **4.2.2 Ageing room**

For lamp ageing, the lamp life test and the switch withstand test, the ambient temperature of the aging room shall be in the range of  $15^\circ\text{C}$  to  $40^\circ\text{C}$ . Some draught is allowed but vibration and shock should be minimised.

### **4.3 Supply**

#### **4.3.1 Test voltage and frequency**

For aging and testing, the lamp shall be at the rated voltage and frequency of the lamp. If the rated voltage is a range, the lamp shall be aged and tested at the **maximum** voltage of that range unless otherwise specified.

#### **4.4 Position of lamp**

Unless otherwise stated for specific purposes, the lamps shall be mounted in a vertical base-up position and operated in free air for all tests including life tests.

#### **4.5 Stabilization time**

For all tests which require a measurement of lumen output, excluding starting and run-up tests, testing shall not begin until the lamp is stable. The lamp shall not be considered stable until repeated measurements of the lamp show a variation in luminous flux of less than 2% per minute. Repeated measurements shall be taken for at least a period of 20 minutes after starting.

#### **4.6 Lamp Aging**

Unless specified elsewhere, lamp aging shall take place in the aging room for the specified number of hours of operation, according to the following cycle:

*lamps shall be cycled repeatedly, such that they are on for 2 hours 45 minutes and off for 15 minutes.*

Aging shall only be deemed to have occurred during the periods when the lamp is on.

## **5 MEASUREMENT EQUIPMENT AND ACCURACY**

### **5.1 Test supply**

The test voltage shall be within +/- 0.1% of the value specified in clause 4.3.1. The test frequency shall be within +/-0.1% of the value specified in clause 4.3.1.

The total harmonic content in the supply voltage for the measurements shall not exceed 3% of the fundamental. The total harmonic content is determined by summation of the individual frequency r.m.s. voltages using the fundamental as 100%.

### **5.2 Ageing supply**

The ageing voltage shall be within +/-1% of the value specified in clause 4.3.1. The ageing frequency shall be within +/- 0.1% of the value specified in clause 4.3.1.

The total harmonic content in the supply voltage for ageing shall not exceed 3% of the fundamental. The total harmonic content is determined by summation of the individual frequency r.m.s. voltages using the fundamental as 100%.

### **5.3 Power measurement**

Measurements of power shall be made with a suitably calibrated wattmeter or power analyzer with an uncertainty of less than or equal to 0.8%. The power measurement instrument shall have the following characteristics:

Bandwidth: 500KHz

Accuracy: 0.01 % for measurement of voltage and current

### **5.4 Luminous flux measurement**

#### **5.4.1 Measurement equipment for tests**

All measurement equipment shall be traced to a national/international laboratory standard.

##### **5.4.1.1 Integrating Sphere**

An integrating sphere of the following dimensions shall be used for the starting time and run up tests:

For lamps where the largest dimension  $\geq 400\text{mm}$ , the sphere shall have a diameter of at least 2.4 m.

For lamps where the largest dimension  $<400\text{mm}$ , the sphere shall have a diameter  $> 6$  times that dimension.

The internal surface of the sphere shall be coated with diffuse non-selective paint in accordance with CIE 84.

The lampholder and supports should be as small as possible and preferably highly reflective. The sphere shall have as small a screen as possible to shield the photometer head from direct illumination, and be positioned between the centrally located light source and the photometer head port, at a distance  $1/3$  to  $2/3$  times the sphere radius from the photometer head port.

##### **5.4.1.2 Goniophotometer (Distribution Photometer)**

The photometer should be designed so the test lamp can be correctly mounted in relation to the photometer optical axes. The photometer must also be capable of determining luminous intensity and necessary angular settings in the test planes of the lamp. In all cases the mounting apparatus should not interfere with light emitted by the lamp.

The distance from the lamp to photometer port shall be at least 6 times the largest dimension of the tested lamp.

Angular settings shall be reproducible within +/-  $1/4$  degree.

When using Method A2 or B (Section 6.5.3) to measure luminous flux, tests shall be made with sensor which has the following characteristics:

Deviation of the relative spectral responsivity from the  $V(\lambda)$  function (f1) shall be +/- 1.5.

UV (u) and IR (r) response of less than 0.2%.

Linearity error (f3) of less than 0.2%.

Cosine correction f2=1.0%

#### **5.4.1.3 Spectroradiometer**

The accuracy of the spectroradiometer shall be better than +/- 0.2 nm over the visible spectrum (380-780nm), and it shall have a wavelength repeatability: 0.1nm and stray light characteristics of  $10^{-5}$ .

### **5.5 Time measurement**

Equipment used to measure time shall be able to determine the results as below:

Starting time: Unit - sec, +/- 0.01

Run-up time: Unit - mins, +/- 0.1

Lifetime: Unit - hours, +/- 1

### **5.6 Mercury content measurement**

Refer to. ANNEX A.

## 6 Test Procedures

### 6.1 Starting Time Test

The starting time test is to be conducted on new lamps.

#### 6.1.1 Test conditions

The test voltage for the starting test shall be equal to 92% of rated lamp voltage. In the case where the lamp is rated for a range of voltages, the test voltage shall be 92% of the minimum value of that range.

The test setup and equipment shall be as shown in Figure 3.

**Figure 3: Set up for Starting time test, Method B**

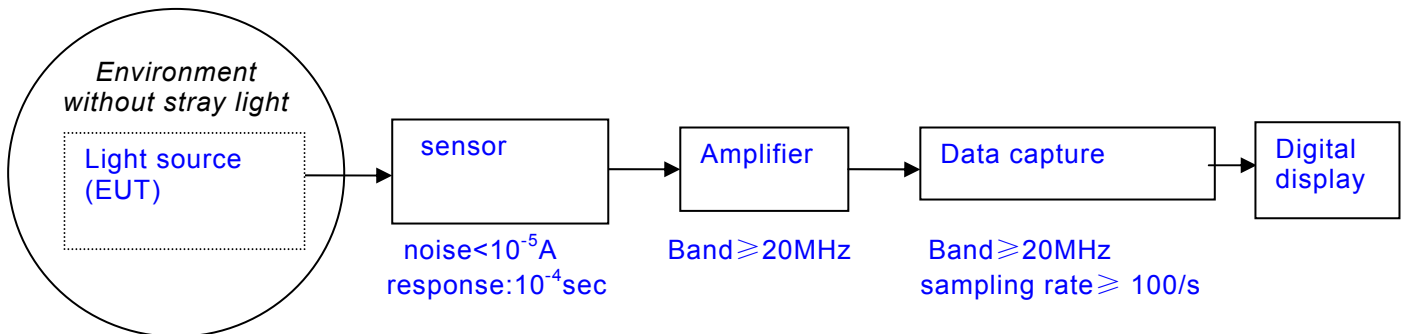

#### 6.1.2 Test Procedure

- 1) The equipments shall be set up as in Figure 3.
- 2) The equipment shall be left to reach a stable condition in the test room for a period of 30 minutes prior to commencement of the test.
- 3) Switch on power to measuring device(s).
- 4) Switch on power to the EUT.
- 5) The test shall run until the lamp is constantly illuminated. If after a reasonable period the lamp does not illuminate, cease the test.
- 6) Record luminous flux and time measurements taken during the test, and details of ambient conditions.

#### 6.1.3 Calculations:

The starting time is determined as the period from the start of the test to when the lumen output reaches the first peak point after which the light output is continual. The starting time should be determined in line with Figures 4 or 5 (Figure 4 should be used where there are pulses before the continual light output, or Figure 5 should be used where there are no pulses before the stable light output).

**Figure 4: Diagram for calculation of Starting time (pulses)**

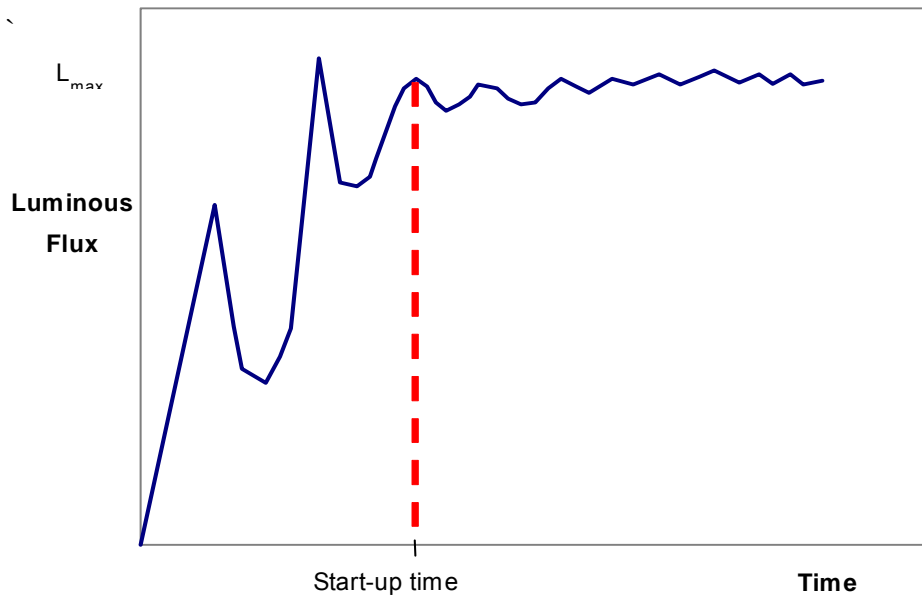

**Figure 5: Diagram for calculation of Starting time (no pulses)**

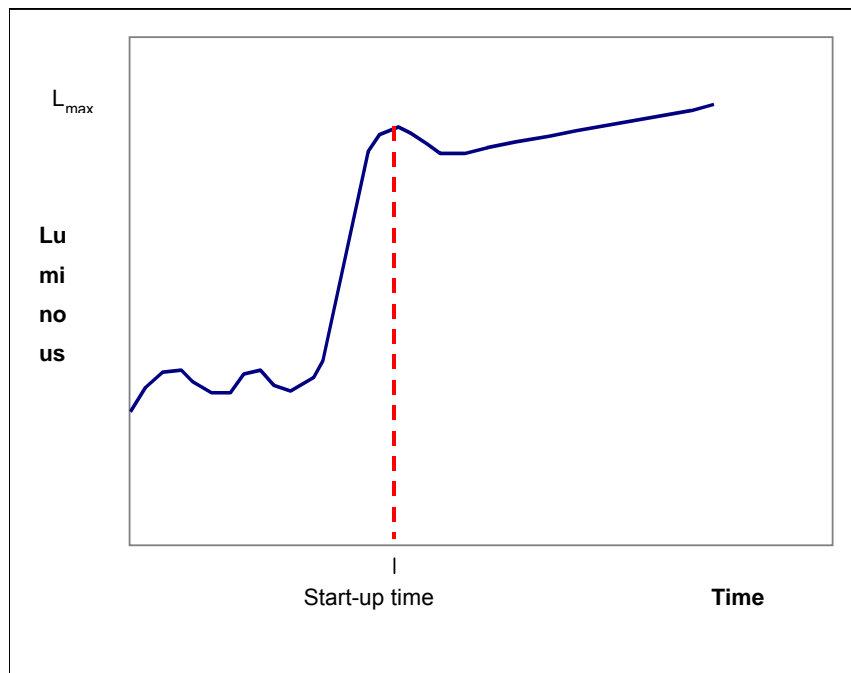

## 6.2 Run-up Test

The Run-up Test is to be conducted on lamps aged for 100 hours.

### 6.2.1 Test Conditions

The test voltage for the Run-up test shall be equal to rated lamp voltage. In the case where the lamp is rated for a range of voltages, the test voltage shall be the midpoint of that range.

The test setup and equipment shall be as shown in Figure 6.

**Figure 6: Test set-up for Run-up test**

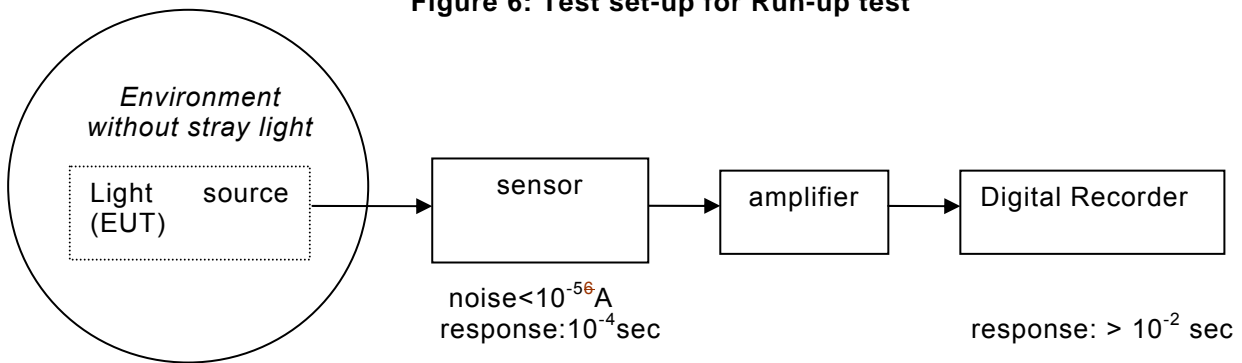

### 6.2.2 Test Procedure

- 1) The equipments shall be set up as in Figure 6.
- 2) After aging the lamp shall be left for at least 24 hours in the aging room before being moved to the test room.
- 3) The equipment shall be left to reach a stable condition in the test room for a period of 30 minutes prior to commencement of the test.
- 4) Switch on power to measuring device(s).
- 5) Switch on power to the EUT.
- 6) The test shall run until the lamp output is stable or 20 minutes, whichever is shorter, where stable lamp output is defined as the variation in luminous flux of less than 2% per minute.
- 7) Record luminous flux and time measurements taken during the test, and details of ambient conditions.

### 6.2.3 Calculations

The Run-up time is calculated as the time taken from the start of the test to when the lamp achieves 80% of the stable lamp output.

Where the lamp does not achieve stability within 20 minutes, run up time should be calculated as the time taken from the start of the test to the point the lamp achieves 80% of the maximum light output within 20 minutes from the start of the test,

## 6.3 Low Temperature Starting Time Test

The Low-temperature Starting Time Test shall be conducted using new lamps.

### 6.3.1 Test Conditions

The test voltage for the Starting Test shall be equal to rated lamp voltage. In the case where the lamp is rated for a range of voltages, the test voltage shall be the lowest voltage of the range.

The lamp shall be placed in a cooling cabinet for 24 hours with a window to allow visual inspection. The cabinet shall be maintained at a stable temperature, as specified elsewhere, within  $\pm 1^\circ\text{K}$  of the specified temperature.

Photometric measuring equipment is not required for this test.

### 6.3.2 Test Procedure

- 1) The EUT shall be switched on and a stopwatch used to record the time when the lamp achieves constant illumination.
- 2) The ability of the lamp to start at the specified temperature shall be confirmed by visual inspection.

3) If the lamp fails to illuminate within 10 seconds, cease the test.

## 6.4 Initial Luminous Flux Test

*Note: the measurement of luminous flux is necessary for a number of the tests detailed later in this standard.*

The measurement of luminous flux is to be conducted on lamps aged for 100 hours.

### 6.4.1 Test Conditions

Three optional methods can be used for the measurement of luminous flux, two using an integrating sphere, one using a photometer. For all lamps types other than reflector lamps, method A1 or A2 (using an integrating sphere) shall be used. For reflector lamps, method B (using a photometer) shall be used.

For all methods the following circuit should be used:

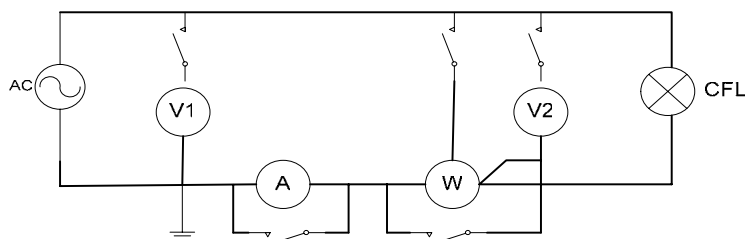

#### 6.4.1.1 Method A1 (Integrating Sphere Measurement: Distribution Photometry) and Method A2 (Integrating Sphere Measurement: Integrating Method)

The lamp shall then be properly mounted inside a sphere as specified in section 5.4.1.1 (integrating sphere).

#### 6.4.1.2 Method B: Goniophotometer (Distribution Photometer)

The lamp shall be mounted within a goniophotometer as specified in section 5.4.1.2 (goniophotometer).

The light centre of the test lamp, that is, the geometric centre of all discharge tubes should be mounted at the centre of the goniophotometer..

The original orientation of the lamp should be selected so that the vertical plane passing the two cathodes is parallel to the 0-degree test plane.

### 6.4.2 Test Procedure

- 1) In all methods the equipment under test should be left to reach a stable condition for at least 30 prior to the commencement of the test.
- 2) In all methods the lamps under test shall be burned until stable, ie where the variation in luminous flux is less than 2% per minute.

#### 6.4.2.1 Method A1 (Integrating Sphere Measurement: Distribution Photometry) and Method A2 (Integrating Sphere Measurement: Integrating Method)

- 1) The lamp shall then be properly mounted inside the sphere, and measurement equipment and the lamp switched on.
- 2) Maintain the temperature around the lamp in accordance with Clause 4.2.1.
- 3) The lamp should be left to stabilise.

- 4) After stabilisation, measurements of all required variables detailed in section 6.4.3.1 or 6.4.3.2 (dependent upon calculation method to be used) shall be taken and recorded.

#### 6.4.2.2 Method B: Goniophotometer (Distribution Photometer)

##### 1) Angles and Planes for Measurement

The vertical angle range shall be from nadir (0 degree) to zenith (180 degree). The vertical angle spaces should be no more than 10 degrees.

Readings should be taken in at least 36 vertical half-planes. That is the horizontal angle spaces should be no more than 10 degrees. The horizontal angles should be counter-clockwise arranged when looking down at the lamp.

##### 2) Stray Light Measurement

Stray light should be measured.

##### 3) Data Processing

All data shall be recorded including:

A sketch to indicate the lamp's center and the lamp's original orientation corresponding to the goniophotometer.

The test distance (ie the distance covered by the light transmitted from the goniophotometer center to the detector)

All lamp and stray light readings

#### 6.4.3 Calculations

##### 6.4.3.1 Method A1: Integrating Sphere Measurement: Distribution Photometry

Luminous flux (lm) can be obtained from total spectrum radiant flux (absolute unit). The luminous flux of test source, represented by  $F_t$ , is calculated by:

$$F_t = K_m \int_{380}^{780} F_s(\lambda) V(\lambda) d\lambda$$

Where

$V(\lambda)$  represents spectral luminous efficiency;

$K_m$  represents the maximum luminous efficacy, 683lm/W;

$F_s(\lambda)$  represents the total spectral radiant flux of the test source.

Note: When the test lamps and the standard source are not of the same size and shape, absorption correction shall be made. The absorption correction is as follow:

$$F_c = F_t \times \alpha$$

Where

$F_t$  represents the luminous flux measured;

$\alpha$  represents the coefficient of absorption correction;

$F_c$  represents the final result after absorption correction.

### 6.4.3.2 Method A2: Integrating Sphere Measurement: Integrating Method

Luminous flux can be calculated by:

$$F_t = (I_t / I_s) \cdot F_s \cdot K \cdot \alpha$$

Where:

$F_t$ ,  $F_s$  represent the luminous flux of the test source and the standard source respectively

$I_t$ ,  $I_s$  represent the photocurrent of the test source and the standard source respectively

If the spectral energy distribution of the test source differs from that of the standard source, colour correction must be undertaken as follows:

$$K = \frac{\int P_t(\lambda)V(\lambda)d\lambda}{\int P_s(\lambda)V(\lambda)d\lambda} \cdot \frac{\int P_s(\lambda)\rho(\lambda) \cdot S(\lambda)d\lambda}{\int P_t(\lambda)\rho(\lambda) \cdot S(\lambda)d\lambda}$$
$$\rho(\lambda) = t(\lambda) \cdot \frac{\rho'(\lambda)}{1 - \rho'(\lambda)}$$

Where,

$K$  represents the coefficient of colour correction

$P_t(\lambda)$ ,  $P_s(\lambda)$  represents the relative spectral power distribution of the test source and the standard source respectively;

$V(\lambda)$  represents spectral luminous efficiency;

$\rho(\lambda)$  Represents the spectral reflectivity of the sphere wall;

$t(\lambda)$  Represents the spectral transmissivity of the window glass of the integrating sphere;

$S(\lambda)$  Represents the relative spectral sensitivity of detector.

Note: When the test lamps and the standard source are not of the same size and shape, absorption correction shall be made. The absorption correction is as follow:

$$F_c = F_t \times \alpha$$

Where

$F_t$  represents the luminous flux measured;

$\alpha$  represents the coefficient of absorption correction;

$F_c$  represents the final result after absorption correction.

### 6.4.3.3 Method B: Goniophotometer (Distribution Photometer)

The stray light data should be subtracted from the original test readings. Luminous flux can then be calculated as follows:

$$F_t = \int_0^\pi \int_0^{2\pi} E(\theta, \varphi) R^2 \sin \theta d\theta d\varphi$$

Where:

$F_t$  represents the luminous flux of the test lamp

$E(\theta, \varphi)$  represents the illuminance value of the spot indicated by the horizontal angle  $\varphi$  and the vertical angle  $\theta$

$\theta$  represents the vertical angle

$\varphi$  represents the horizontal angle

$R$  represents the test distance

## **6.5 Initial Efficacy Test**

### **6.5.1 Test Procedure**

- 1) Follow the procedure for measurement of initial luminous flux (section 6.4) but measure lamp power simultaneously with measurements for the calculation of luminous flux and record the data.

### **6.5.2 Calculations**

Following the calculation of luminous flux (see section 6.4), initial efficacy is calculated as follows:

(lumen flux) / (measured lamp power)      Units: lm/w

## **6.6 Lumen Maintenance and Maintained Efficacy Tests**

The sample of lamps that underwent initial efficacy tests shall be aged in the aging room as described in Clause 4.6 for the specified number of hours.

Unless specified elsewhere, the lumen maintenance test shall be undertaken after 2,000 hours of operation.

Further lumen maintenance tests may be performed at specified periods. One of these tests may be performed at the manufacturer's rated average lamp life.

### **6.6.1 Test Procedure**

- 1) Follow the procedure for measurement of initial luminous flux (section 6.4) and initial efficacy (section 6.5) tests.

### **6.6.2 Calculations**

- 1) Follow the calculation methods for measurement of initial luminous flux (section 6.4) and initial efficacy (section 6.5) tests.

## **6.7 Lamp Life Test**

The test conditions shall be as described in Section 4 and 5.

The sample of lamps that underwent initial efficacy tests shall be aged in the aging room as described in Clause 4.6 for the specified number of hours.

The hours of operation shall be recorded for each lamp, until lamp failure as defined in 3.5. Failure may be determined by inspection, photo-sensors or by a separate lumen maintenance test.

Recorded hours of operation shall only include the periods of the cycle when the lamp was on. Hours of operation shall include the initial aging period.

### **6.8 Switching Withstand Test**

The Switching Withstand test shall be conducted on lamps aged for 100 hours.

The test conditions and equipment shall be as specified in the lamp life test.

The switching cycle used for the Switching Withstand test shall be 10 sec on, 5 minutes 50 sec off.

Unless otherwise specified, the number of cycles of the test should be equivalent to twice the rated lamp life expressed in hours (for example, a lamp with a rated life of 1,000 hours should be tested for 2,000 cycles).

If the lamp fails during the test period, the lamp is deemed to have failed the test.

### **6.9 Test for Colour Appearance and Rendering Index**

The chromaticity co-ordinates (Correlated colour temperature) and colour rendering index (CRI) tests shall be performed on lamps aged for 100 hours. The chromaticity co-ordinates shall be measured with a spectroradiometer in accordance with CIE 63:1984.

While testing, it should be noted that the beam of the standard source and that of the test source should enter the spectrometer under the same geometry conditions and the beams should irradiate the incident slit completely and uniformly.

### **6.10 Light Distribution Test**

The Light Distribution test shall be performed on lamps aged for 100 hours.

The test voltage shall be equal to the rated voltage, except where the lamp is rated at a voltage range, in which case the mid-point voltage shall be used.

After stabilisation, the Nadir measurement shall be taken with a goniophotometer, and sufficient measurements at 90 degrees from the Nadir to determine an average of the 90 degree plane. The light distribution ratio is calculated as:

$$\text{(The light intensity at Nadir)} / \text{(The average of light intensities at 90 degrees to Nadir)}$$

### **6.11 Power Factor Test**

The Power Factor test shall be performed on lamps aged for 100 hours.

The lamp shall be set-up in accordance with Section 4 and 5, and the power factor calculated.

### **6.12 Test for Electromagnetic Compatibility (EMC)**

Refer to appropriate part of IEC 61000

### **6.13 Mercury Content Test**

Tests for mercury content of lamps shall be carried out on a separate sample of lamps in accordance ANNEX A.

## **7 Sample Sizes for Tests**

The minimum number of samples used for each test shall be as follows:

Starting Time:	10
Run-up:	10
Initial Efficacy:	10
Lumen maintenance:	10
Lifetime:	10
Switching Withstand:	6
Colour:	10
Cold Start:	6
Light Distribution:	6

## **8 TEST REPORT**

See ANNEX C

## **Annex A**

(normative)

### **Method for Determining the Mercury Content in lamps**

#### **A.1 GENERAL**

##### **A.1.1 SCOPE**

This standard specifies a method of test to determine the quantity of mercury (Hg) present in any type of fluorescent lamp, excluding mercury present in the vapour state.

This test method specifies the procedures which can be used to determine accurately the mercury content of any type of fluorescent lamp in which mercury has been introduced as the carrying agent for the discharge between the electrodes.

The method involves the chemical digestion of the mercury contained within a lamp and the determination of that mercury content on a per lamp basis. This is achieved using a method of solubilisation of the entire mercury content contained within the tube using acidic digestion methods and the accurate determination of that mercury content using standard mercury solutions to determine that mercury content. This will allow comparison between the mercury content of different lamps and with internationally accepted standards set for lamp mercury content.

#### **A.2 DEFINITIONS**

For the purpose of the standard the following definitions apply.

##### **A.2.1**

###### **Fluorescent Lamp**

A discharge lamp of the low pressure type, in which most of the light is emitted by one of several layers of phosphors excited by the ultra-violet radiation from the discharge from the electrodes.

##### **A.2.2**

###### **Double capped fluorescent lamp**

Fluorescent lamp having two separate caps and mostly of tubular form and linear shape.

##### **A.2.3**

###### **Single capped fluorescent lamp**

Fluorescent lamp with a single type cap but with the discharge tube bent or formed into a spiral or convoluted tube. These may or may not contain Mercury as amalgams.

##### **A.2.4**

###### **Discharge electrodes**

Discharge electrodes are located in the lamp caps and may be of simple tungsten wire design, or may comprise a grid or container in which a mercury amalgam is present.

##### **A.2.5**

###### **Mercury and amalgams**

Mercury in fluorescent lamps is generally free mercury or mercury vapour under discharge which provides the conducting agent between the electrodes. Mercury in fluorescent lamps may exist in three possible states as followed:

- 1) Vapour in a lamp
- 2) Liquid metal or in an oxidised state.
- 3) An amalgam of mercury with another metal such as Titanium (Ti), or Bismuth (Bi).

This test method determines the total amount of mercury present as either liquid metal, or oxidised state, or in an amalgam. Mercury in the vapour state is not determined but represents only a very minor fraction of any mercury and can for all practical purposes be ignored in the determination.

### **A.2.6**

#### **Lamp samples**

A minimum of three samples of the same model lamp, selected from the same manufacturer's batch, should be used to determine the mercury content of the lamp model.

In order to select the correct digestion procedure(s), it must be determined prior to the start of the analysis whether the lamp contains a mercury amalgam.

### **A.2.7**

#### **Measurement equipment**

The equipment used for preparing and measuring the sample for determination of mercury.

### **A.2.8**

#### **ICP-OES**

An inductively coupled plasma optical emission spectrophotometer used for the determination and calculation of the mercury content of the final sample.

## **A.3 GENERAL TEST PROCEDURE**

Test conditions are set up to determine the mercury content in a series of at least three lamps of the same type by breaking the lamp itself under controlled and captive conditions (Method 1) or breaking the vacuum seal of the lamp to allow the interior contents to be accessed (Method 2).

The method and procedures described in this document are to take place in a controlled environment of a chemical laboratory. All safety precautions shall be used for the protection of the laboratory analyst from the lamps, the destruction of the lamps and the mercury and any other phosphor content of the lamps. The procedures must be carried out in the safety of a chemical laboratory equipped for the handling of hot acids, mercury and glass materials using the appropriate fume cupboards and other hazard protection equipment. All materials are to be disposed of using proper disposal procedures for these types of wastes including mercury wastes.

The total mercury in the lamp is determined by dissolving the entire mercury content in any of its forms in a suitable acid mixture to ensure all mercury is entirely dissolved from the interior contents of the lamp.

The method then measures the mercury in the dissolved acid mixture taking account of the actual volume of acid used in the determination and measurement of the mercury in the acid samples using the methods of inductively coupled plasma with optical emission spectra measured in the spectrophotometer (ICP-OES). The mercury readings from the emission spectra are then calculated against known prepared mercury standard solutions to calculate the actual mercury content for each lamp or batch of lamps.

## **A.4 MEASUREMENT EQUIPMENT**

### **A.4.1 PREPARATION EQUIPMENT REQUIRED – METHOD 1**

Pliers and sharp knife

Beakers, volumetric flasks, measuring cylinders

Disposable 3ml plastic transfer pipettes

Putty or plasticine or similar

Automatic pipettors to dispense specific volumes and disposable tips

0.45 micron filters suitable for acid solutions of up to 200 ml.

Glass scoring file, heating wire and heater, hammer

Electric hot plate suitable for heating the acid in the bulb itself, or beaker

Safety gloves (teflon type)

Acid protective equipment, gloves and safety glasses, lab coat.

#### **A.4.2 REAGENTS- METHOD 1**

Nitric acid,  $\text{HNO}_3$ , concentrated, 70%

Water: High Grade Distilled water or Milli Q.

Dilute Nitric acid (1+1): Equal volumes of nitric acid, 70% and water. The nitric acid shall be added to the water and mixed. Caution: A high amount of heat transfer occurs during mixing. Always add acid to water.

Standard solution of mercury salts ie 1000mg per litre mercuric nitrate purchased from an appropriate supplier.

Diluted standard solutions, standard mercury solution diluted in deionised water. Mercury standard solution should be diluted on the day of measurement.

#### **A.4.3 ADDITIONAL EQUIPMENT FOR METHOD 2**

Round-bottomed flask of type suitable for reflux procedures, which includes one glass stoppered side arm

Reflux condenser

Electric heating mantle for round-bottomed flask for refluxing

#### **A.4.4 ADDITIONAL REAGENTS FOR METHOD 2**

Hydrochloric acid,  $\text{HCl}$ , concentrated, 37%

Aqua regia: concentrated nitric acid is mixed with three times the volume of concentrated hydrochloric acid. Use caution when making this solution.

Sulphuric acid,  $\text{H}_2\text{SO}_4$ , 98%

Sulphuric acid (1+1): Equal volumes of sulphuric acid and water. Caution: A high amount of heat transfer occurs during mixing. Always add acid to water.

NOTE: All chemicals must be high quality analytical reagent (AR) grade

#### **A.4.5 INSTRUMENTS**

##### **Inductively Coupled Plasma -Optical Emission Spectrometer (ICP-OES):**

The instrument which gives light emission intensity with suitable sensitivity and stability in the directed measurement and concentration range for detection of the mercury emission spectra. Refer to the specific operating manuals for such instruments. Suitable instruments are manufactured by a number of manufacturers and are available in suitably equipped inorganic chemistry laboratories.

##### **Gas:**

High quality pure, inert Argon gas, is used as the principle carrying gas for the plasma torch of the instrument.

An example of the principle of an ICP-OES is shown in Fig. A1.

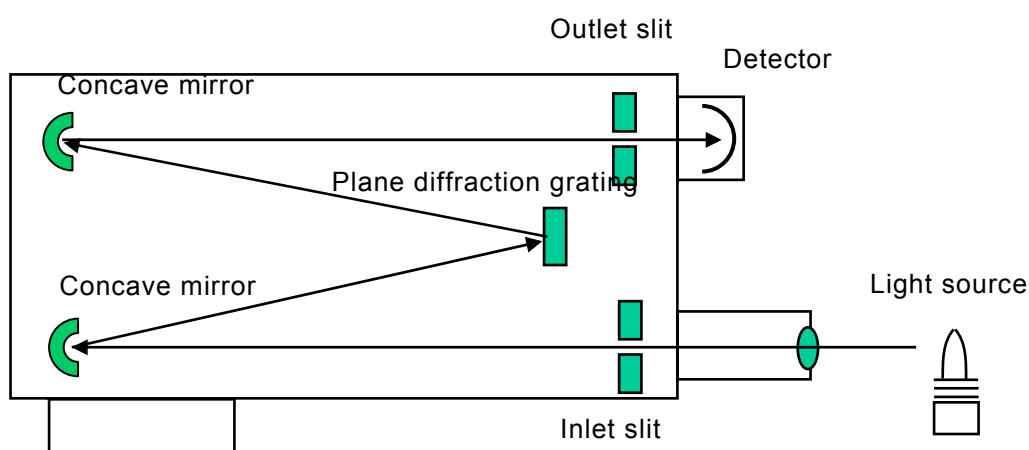

Fig.A1 Spectrophotometry part using sequential type spectroscope (an example)

## A.5 TEST SETUP

### A.5.1 LAMPS

The test of lamps is setup by obtaining a selection of lamps that are required to be tested. These should be clearly labelled as samples for test and require a minimum of three lamps of identical type and markings from the same manufacturing run. Groups or batches of lamps separately labelled may be tested in parallel provided all samples are separately coded and recorded throughout the determination procedure.

### A.5.2 LABORATORY

A suitably equipped inorganic chemical laboratory with separate wet chemistry preparation areas is required. Mercury preparations and acids shall be handled in an acid-suitable, fume cupboard. Preparation areas and safety equipment maintained according to relevant standards.

Lamps shall not be broken or treated in a laboratory where other mercury determinations are being made. All lamp handling and acid preparation procedures must be carried out in a separate preparation laboratory to the measuring equipment, and equipped with a suitable fume cupboard.

Proper procedures for disposal of all materials, glass, metal and acids shall be available at the laboratory location.

### A.5.3 SAMPLE SETUP

#### A.5.3.1 Labelling

All lamps to be tested shall be labelled and all manufacturer's marks recorded onto separate test sheets clearly identifying each lamp sample.

All beakers, flasks, plastic containers or bags used for holding acid digestions for determination shall be separately labelled and recorded on test sheets.

#### A.5.3.2 Acids

All acids required, dilutions or mixtures of acids shall be prepared in the fume cupboard and separately labelled and recorded.

#### A.5.3.3 Standard solutions

All standard solutions required for measurement and determination of concentration shall be separately prepared and recorded in standards test sheet records.

#### **A.5.3.4 Preparation equipment**

All minor equipment, glassware and plastic equipment and heating equipment shall be collected, prepared and tested to ensure its reliability, accuracy and functionality.

All measuring equipment used, volumetric flasks, pipettes, dilution equipment, pipettors shall be checked to ensure that they are delivering correct volumes and amounts as required in the procedure.

#### **A.5.4 MEASURING EQUIPMENT SETUP**

The ICP-OES used for measuring the concentration of mercury in the final sample solutions shall be separately maintained according to the manufacturer's specifications. The daily maintenance checks and records of the instrument's performance in measuring the various elements will normally be a routine procedure of the laboratory measuring the elements. These routine laboratory quality procedures are to be followed and the instrument checked for accuracy and reliability of measurement for the mercury emission spectra using the standard procedures in place for the ICP-OES instrument.

Appropriate procedures for the automatic sampling equipment and argon gas supplies are also to be checked according to routine daily laboratory procedures.

### **A.6 TEST PROCEDURES**

Two test methods are described below:

Method A or Method B may be used for fluorescent lamps not containing mercury in amalgam form.

Method B shall be for fluorescent lamps containing mercury in amalgam form.

#### **A.6.1 METHOD A: MERCURY DECOMPOSITION IN A LAMP BULB NOT CONTAINING AMALGAMS**

The metal caps of the fluorescent tubes shall be removed. This may be done by twisting off the caps with pliers while holding the tube wrapped in paper towel to prevent glass injury. This will break the cement holding the caps and the wires.

At one end of the tube, break the small central inner glass tube used to evacuate the tube. This may be done using pliers.

Introduce the required amount of diluted nitric acid into the lamp using a 3ml plastic transfer pipette. Acid shall be introduced in 3ml lots while rotating the tube so that the phosphor is washed off the inside of the tube.

Once the required amount of acid is introduced, the broken end of the evacuation tube shall be plugged with a small amount of putty, plasticine or similar, and the tube inverted several times to wash the insides of the tube and filaments so that all phosphor is removed.

The lamp shall then be placed vertically into the preheated hot plate designed for the purpose and maintained at between 80°C to 100°C for 50 minutes. The tube shall be inverted every 10 to 15 minutes to ensure that the filament parts at the top end of the lamp are washed in hot nitric acid.

Following (e), hold the lamp over a beaker and again carefully break the evacuation tube at the other bottom end of the tube with pliers and allow the solution to run into a beaker.

Introduce another 20 ml of diluted nitric acid into the lamp through the upper evacuation tube while holding over the beaker, rotating the tube to ensure all the inside is washed. Hold the tube horizontally and rotate carefully then allow the solution to run into the beaker. Wash the tube with a further 20 ml of water ensuring that all parts of the tube is washed thoroughly. Collect all washes. The final volume should be less than 200 ml.

The final solution shall be filtered through a 0.45 micron filter into a volumetric flask. Water shall be added to make up a total volume of 200 ml.

This solution is then diluted as required and appropriate samples analysed using ICP-OES. The analysis must include a minimum of three samples of any light bulb batch as well as the blanks and standards.

### A.6.2 METHOD B: MERCURY DECOMPOSITION IN A LAMP BULB CONTAINING AMALGAMS.

Remove the plastic base and base cement completely with a knife, or pliers from the bulb.

Score the bulb with an appropriate glass scoring file on or near the end of the tube with a file.

Heat a glass rod or Nickel/Chromium wire to red heat and touch the score line to crack the bulb and allow the lamp bulb leak to atmospheric pressure.

Take out the amalgams from the inside of the tube and dissolve them in accordance with the method given below.

Wet all of inside of the bulb with water in order to prevent losing mercury contained in the dry phosphor coating when the bulb is broken into pieces. Collect the water in a beaker.

Put the bulb into a thick plastic bag and break it by hitting the bulb from outside the plastic bag with a hammer or heavy object (see figure A2), or break the bulb inside a beaker, jar or similar container depending on the size of the bulb with pincers or pliers. (In order to prevent the plastic bag from being cut, pincers or pliers can be used to break up into smaller pieces).

*Note:* An alternative method that can be used is to use a suitable glass or plastic flask or other lidded container in which to break the pieces, then smashing the contents further with a large porcelain or glass ball (toy marble).

In either case, with a plastic bag or flask it is intended to minimise injury to the operator as well as contain all pieces of glass. Ensure complete digestion of all the contents.

Tip all the pieces from the bag into a beaker and rinse inside the plastic bag or container with known amount of water.

Make up the volume of solution in the beaker containing water with concentrated nitric acid to be a 1+1 concentration (about 30 ml). Stir or wash the pieces around the container with a glass rod until no more phosphor comes off from the pieces of glass. Heat the beaker on a hot plate and keep at about 80 °C for 50 minutes.

Cool the solution to room temperature. Filter through a 0.45 micron filter. Transfer the filtrate and filter washings into a volumetric flask and water added to make up to an appropriate volume<sup>(1)(2)(3)</sup>.

#### Notes

<sup>(1)</sup>This sample solution can be stored for a week, however diluted test solutions should be measured on the same day.

<sup>(2)</sup>The amount of diluent depends on the size and shape of the lamp, since the mercury content of the lamp tube with the amalgam removed from the lamp may be very small, the amount of diluent should be small as possible.

<sup>(3)</sup> In the case of a lamp containing an amalgam do not make up to final volume until the solution from Section 6.2.1 or 6.2.3 is added to the flask.

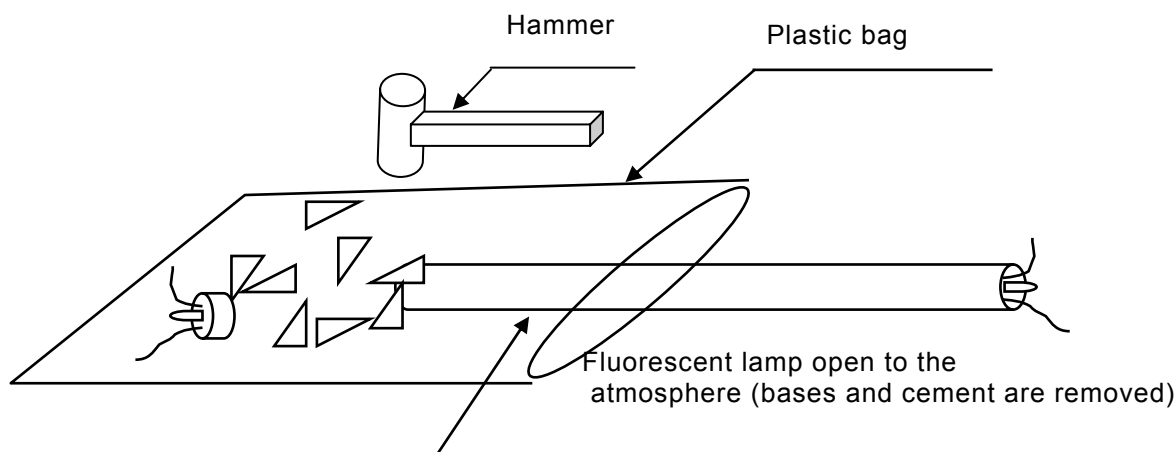

Fig. A2 Method of lamp destruction using the plastic bag method.

### A.6.2.1 Decomposition of mercury amalgams: Titanium amalgam

An example of a titanium amalgam contained in a fluorescent lamp is shown in Fig.A3

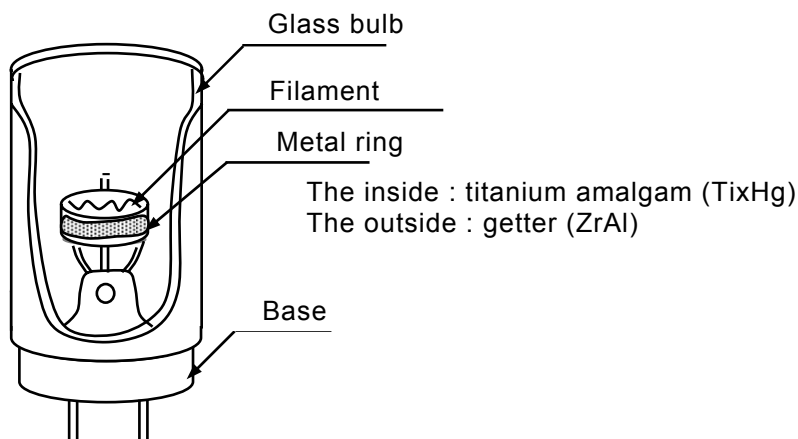

Fig.A3 Example of titanium amalgam in a fluorescent lamp electrode

Take amalgam with metal ring from inside of a lamp after using procedure described in the previous section and put it in a round-bottomed flask.

Connect a reflux condenser to the round-bottomed flask, place into a heating mantle which is placed in a fume cupboard. Ensure that the cooling water is flowing through the condenser.

Add 10ml of dilute sulphuric acid (1+1) through the side arm and heat gently for about 30 minutes.

Add 5 ml of dilute nitric acid (1+1) through the side arm and heat until white fumes are observed.

Add 5 ml of dilute nitric acid (1+1) through the side arm and heat until any salts which have formed have completely dissolved.

Cool the contents and proceed to filter and make up in a volumetric flask to a known volume as previously described. Record all final volumes on the test sheets.

If the amalgam is within a bulb, add this filtered solution to that of the solution in the volumetric flask from A6.2 J.

### A.6.2.2 For other types of amalgam pellet and amalgam mesh containing lamps

An example of amalgam pellets and amalgam mesh contained in a fluorescent lamp are shown in Fig.A4

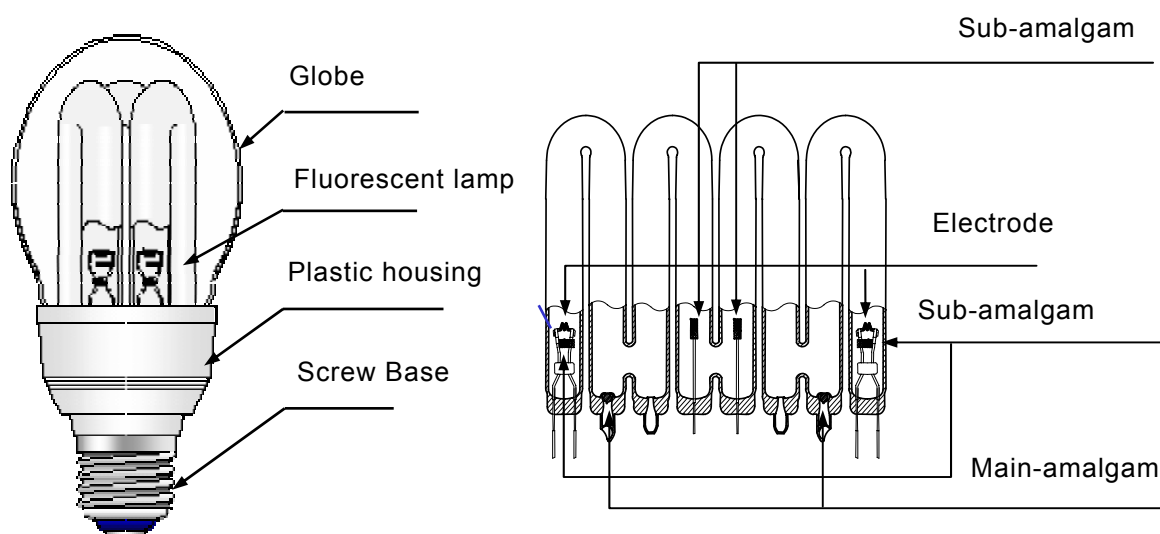

Fig.A4 Examples of amalgam pellets and amalgam mesh contained in fluorescent lamps.

Remove the fluorescent lamp carefully from the plastic housing using a knife or pliers as appropriate.

Let the fluorescent lamp leak slowly to atmosphere using procedure above A6.2, break open the tube and take out the amalgam pellet and the amalgam mesh from the fluorescent lamp.

Put them into a beaker and add 10 ml of aqua regia.

Heat for 90 minutes at 80°C.

After cooling the sample solution to room temperature, filter the solution through a 0.45 micron filter and transferred to an appropriate volumetric flask. Rinse the filter with water thoroughly and add water to marked line of a volumetric flask to make up the test solution (see note).

Note:

When the solution contains Bismuth, deposition of Bismuth may occur in accordance with a drop in acidity. Ensure aqua regia concentration exceeds 10% of the total volume within the volumetric flask.

### A.6.3 SAMPLES FOR MEASUREMENT.

All samples are then transferred to 15 ml plastic tubes in an appropriate sample volume to the automated sampler on the ICP-OES. The volumes are recorded and appropriate blanks, duplicates and standard dilutions added to the sampling rack.

## A.7 MEASUREMENT

### A.7.1 INDUCTIVELY COUPLED PLASMA-OPTICAL EMISSION SPECTROPHOTOMETRY

#### A.7.1.1 General

After dissolving mercury from the lamp and/or amalgams by using nitric acid or other acids, the insoluble components are removed by filtering and the filtered solution made up to an appropriate volume. The appropriately diluted sample solutions are sprayed into plasma on the ICP-OES and the intensity of optical emission of mercury is measured and the mercury concentration for the whole lamp determined using procedures developed for the instrument.

### A.7.1.2 Instruments

ICP-OES - The instrument that gives light emission intensity with suitable sensitivity and stability in the directed measurement and concentration range. This type of instrument is made by several manufacturers.

Gas: pure inert Argon gas as carrier gas into the plasma.

Note: See Figure 1 above for principle of ICP-OES.

### A.7.1.3 Setting of measuring conditions

There is a possibility of memory effect when low mercury concentration sample is measured after a high mercury concentration sample. To avoid the memory effect, ensure that the rinse time is adequate. This is confirmed by analysing known standard solutions and determining that the concentration assayed is correct.

Note: Plasma output, photometric height, flow rate of carrier gas, etc. are varied to set for optimum conditions. These are determined by the trained instrument operator according to normal measurement conditions for the instrument at that time.

### A.7.1.4 Quantitative analysis from the ICP-OES

Select the mercury analytical line at wavelength of 194.2 nanometres (nm) for measuring light emission intensity. When spectral interference is found not to exist, the analytical line at 253.7nm or the other spectral line may be used.

As any coexisting elements other than mercury in the sample solution could have spectral interference on the mercury analytical line, a mercury spectral line without spectral interference should be selected by scanning around the mercury analytical line with spraying sample solution into the plasma<sup>(1)</sup>.

To avoid any effects of the phosphor in the matrix, a standard addition method should be used<sup>(2)</sup>. At least four solutions are sampled by an equal amount from the test solution to prepare one kind of solution wherein the mercury element is not added and at least three kinds of solutions wherein the mercury element is added respectively at different concentrations.

The solutions are sprayed into the plasma and the intensity of atomic emission of mercury is measured. The relation curve between the light emission intensity of the mercury element in the test solution is obtained from the intercept on the axis of abscissa (concentration).

Calculate the amount of mercury in the florescent lamp with the following formula:

$$W=A \times C \times V / 1000$$

Where, W : amount of mercury in fluorescent lamp (mg)

A : dilution rate

C : mercury concentration of test solution ( $\mu\text{g Hg/ml}$ )

V : amount of test solution (ml)

#### Notes

<sup>(1)</sup> As the line spectrum and continuous spectrum by a plasma composing component and a coexisting element are occasionally superimposed with each other for the analytical line as spectral interference, it is recommended that an analytical line with no spectral interference should be used. When spectral interference exists, the degree of the interference calculated as the concentration of mercury should be less than 1/100 of the concentration of mercury of the test solution by using a synthetic matrix solution.

<sup>(2)</sup> This method can be applied only to the case of no spectral interference, or where the background and the spectral interference are regularly corrected and the calibration line between the light emission intensity and the concentration remains linear in the low concentration area or area required for measurement (see Figure 5)

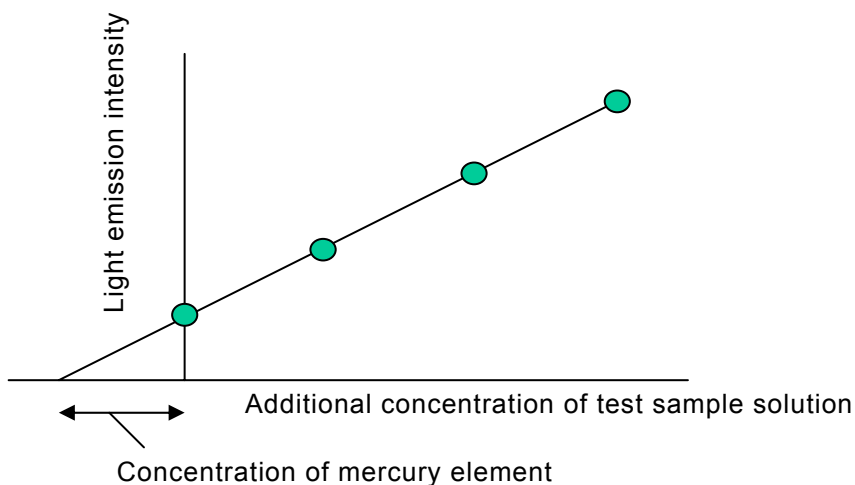

Fig. A5 Method for obtaining concentration by standard additional method

## A.8 REPORTING

All results from the measurement of solutions and all calculations should be recorded onto test sheets. The results are determined for the milligram amounts of mercury per lamp as an average of the three lamps used to determine the concentration for each particular type of lamp. All results should be recorded on a suitable report indicating the results expressed as milligrams mercury per lamp and also contain the quality report determination of the results of any blanks or standards measured in the same determination. Results of reports and calculations should be checked by a second chemist.

### A.8.1 MEASUREMENT UNCERTAINTY.

Ideally the three determinations of mercury per lamp should show good agreement with a measurement uncertainty of <10%. The standard deviation for the measurement can be determined from the measurements where there is good agreement in the three results. If there is not good agreement, the measurement uncertainty will be large and this may require that more than three lamps of the same type( eg 10 lamps) be tested to get a better standard deviation measure. Alternatively, poor agreement of three mercury results with the same type of lamp from the same manufactured batch may indicate uneven injection of Mercury into each lamp and poor manufacturing practice.

## Annex B

### Performance Mark

(Normative)

#### B.1 REQUIREMENT

When a compact fluorescent lamp (CFL) has a performance mark, the lamp shall be clearly and permanently marked with a numeral from the sequence I to X, indicating the performance of the CFL.

A CFL shall be marked with the appropriate numeral when it meets, or exceeds, the efficiency requirements associated with that numeral at all voltage and frequency values it is designed to operate at. The associated requirements for each numeral are shown in Table A1.

TABLE A1

#### PERFORMANCE REQUIREMENTS FOR EACH NUMERAL

Mark	Performance Level
I	Used if it does not meet any of the following criteria
II	t.b.a
III	t.b.a
IV	t.b.a
V	t.b.a
VI	t.b.a
VII – X	Reserved for future use

#### B.2 DESIGN OF THE PERFORMANCE MARK

The characteristics of the mark shall conform to the following description:

Format: Roman numeral: I, II, III, IV, V, VI, VII, VIII, IX or X.

Numerals VI to X are reserved for future use.

Font: Times Roman preferred, but other plain serif fonts are acceptable

Colour: Text to contrast with the background colour.

Placement: On the CFL, with the exact location to be at the discretion of the manufacturer.

The mark shall be legible and indelible

An example of the mark is shown in Figure A1.

FIGURE B1 EXAMPLE OF NUMERAL INDICATING PERFORMANCE



## **Annex C**

### **Test Report (informative)**

The following information shall be recorded in the test report:

#### **1.1 Appliance (equipment) details:**

- (a) brand, model, type, and serial number.
- (b) product description, *as appropriate*
- (c) rated voltage(s) and frequency(frequencies)
- (d) details of manufacturer marked on the product (if any)

#### **1.2 Test Parameters**

- (a) ambient temperature (°C).
- (b) test voltage(s) (V) and frequency (frequencies) (Hz).
- (c) total harmonic distortion of the electricity supply system
- (d) information and documentation on the instrumentation, set-up and circuits used for electrical testing.

#### **1.3 Measured data**

**To be added**

#### **1.4 Test and laboratory details**

- (a) test report number/reference
  - (b) date of test
  - (c) laboratory name and address
  - (d) test officer(s)
-