

SELF-BALLASTED COMPACT FLUORESCENT LAMPS – METHODS FOR MEASURING THE PERFORMANCE

FOREWORD

At the Right Light 6 conference in Shanghai in May 2005, Government and Industry representatives agreed to work towards the harmonisation of test methods and performance requirements for self-ballasted compact fluorescent lamps over a 2 year period.

A comparison of existing test methods used by a number of countries in APEC (the comparison is also believed to be valid worldwide) has clearly shown that for many performance criteria these test methods are very similar and there is great potential for harmonisation based around the existing IEC protocol. However, discussions with a variety of test laboratories demonstrate that the existing test methods require considerable interpretation and this may also introduce variations in results, depending upon the assumptions made by individual laboratories. As a consequence, there is a need not only for a single test method, but one which is sufficiently clear and robust that it can be easily followed, and the results replicated by different laboratories.

In addition, the existing test methods do not all specify the full range of tests relating to the performance criteria of most CFL programs. Having all potential tests contained within the single test method will also clarify the requirements for manufacturers and laboratories, and improve the potential for products to conform to programme requirements.

This document is the first draft of a new Test Method for electronic self-ballasted CFLs and is largely based on the existing test methods, such as IEC 60969. However unlike 60969 it contains no performance requirements and only describes relevant test methodologies. It has drawn on work done by the Joint Standards Australia/Standards New Zealand Technical Committee EL-041-08, and by the NLTC in Beijing.

It is envisaged that the proposed set of performance requirements will be included in a separate document, at a later stage.

It is recognised that this draft still requires considerable refinement. However, in order to gain some preliminary feedback at the Conference in Korea on November 1, the organisers thought it useful to issue this draft for public comment. We welcome any comments on this document either in Korea or by written or email correspondence.

Comments should be provided to:

Stuart Jeffcott

Email: stuart@jeffcott.fsworld.co.uk

CONTENTS

1	Scope.....	4
2	Normative references	4
3	Terms, definitions, symbols and dimensions.....	5
3.1	Terms and definitions	5
4	General conditions for measurement of photometric and electrical characteristics ...	8
4.1	GENERAL.....	8
4.2	Air movement and temperature	8
4.3	Supply.....	8
4.4	Position of lamp.....	8
4.5	Stabilization time	8
4.6	Lamp Aging	8
5	MEASUREMENT EQUIPMENT AND ACCURACY.....	9
5.1	TEST SUPPLY	9
5.2	AGEING SUPPLY.....	9
5.3	Power measurement.....	9
5.4	Luminous flux measurement	9
5.5	Time measurement.....	10
5.6	Mercury content measurement.....	10
6	TEST PROCEDURES	11
6.1	Starting Time Test	11
6.2	Run-up Test	13
6.3	Calculations:	14
6.4	Low Temperature Starting Time Test.....	14
6.5	Initial Efficacy Test	15
6.6	Lumen Maintenance and Maintained Efficacy Tests	18
6.7	Lamp Life Test.....	18
6.8	Switching Withstand Test.....	19
6.9	Test for Colour Appearance and Rendering Index.....	19
6.10	Light Distribution Test.....	19
6.11	Power Factor Test	19
6.12	Test for Electromagnetic Compatibility (EMC).....	20
6.13	Mercury Content Test	20
7	Sample Sizes for Tests	21
8	Marking Requirements	21
9	TEST REPORT.....	21
Annex A	22
A.1	General	22
A.2	Definitions	22
A.3	General Test Procedure.....	23
A.4	Measurement Equipment	23
A.5	Test Setup.....	25
A.6	Test Procedures	26
A.7	Measurement	29
A.8	Reporting	31
Annex B	32
(Normative)	32
B.1	REQUIREMENT	32
B.2	DESIGN OF THE PERFORMANCE MARK.....	32

Annex C	34
1.1 Appliance (equipment) details:	34
1.2 Test Parameters	34
1.3 Measured data	34
1.4 Test and laboratory details.....	34

SELF-BALLASTED COMPACT FLUORESCENT LAMPS – METHODS FOR MEASURING THE PERFORMANCE

1 Scope

This International Standard specifies the test methods and conditions required for electronic self-ballasted, compact fluorescent lamps, with integrated means for starting, controlling and stable operation.

This Standard is applicable for self-ballasted CFLs of all voltages and wattages irrespective of the type of lamp cap. This standard excludes cold cathode and non-general purpose lighting CFLs.

This Standard further specifies test methods for the following:

- Efficacy.
- Starting time.
- Low temperature starting.
- Run-up time.
- Lumen maintenance.
- Lamp life (average)
- Premature lamp failure
- Switching withstand.
- Colour appearance and colour rendering index.
- Light distribution.
- Power factor.
- EMC (incl Harmonics).
- Mercury content.

This Standard also identifies information to be included in the Test report. See Appendix C.

Safety requirements are additional requirements that are not covered in this Standard.

2 Normative references

The following referenced documents are indispensable for the application of this document. For dated references, only the edition cited applies. For undated references, the latest edition of the referenced document (including any amendments) applies.

CIE 13.3, *Method of measuring and specifying colour rendering of light sources*

CIE 63, *The spectroradiometric measurement of light sources*

CIE 69, *Methods of characterizing illuminance meters and luminance meters:
Performance, characteristics and specifications*

CIE 84, *Measurement of luminous flux*

CIE 121, *The photometry and goniophotometry of luminaires*

IEC 60050(845), *International Electrotechnical Vocabulary*

3 Terms, definitions, symbols and dimensions

3.1 Terms and definitions

For the purposes of this document, the following definitions apply.

For definitions relating to lighting, see IEC 6005(845).

3.1.1 Equipment Under Test (EUT)

The equipment under test, in this case a compact fluorescent lamp.

3.1.2 Hours of operation

The number of hours of operation is the time in hours when the lamp is illuminated. Note that this excludes any period when the lamp is switched off.

3.1.3 Initial luminous efficacy

Initial efficacy is the efficacy measured on a new lamp after 100 h of aging. Symbol: F_{100} , units: lumens watts⁻¹.

3.1.4 Initial values

The photometric, and electrical characteristics of a new lamp at the end of the 100 h of aging.

3.1.5 Lamp failure

If the luminous flux of a lamp falls to <50% of its initial value, then the “Lamp failure” is deemed to have occurred, ie the lamp shall be deemed to have reached the end of its life.

3.1.6 Lamp life (of an individual lamp)

As defined by the IEC based on the “lamp failure” criteria defined in this standard

3.1.7 Average lamp life

The length of time in hours at which 50 percent of tested lamps fail.

3.1.8 Light distribution ratio

The quotient of light intensity at Nadir, to the average of light intensities at 90 degrees to Nadir, when the lamp is mounted in a vertical base-up position.

3.1.9 Maintained efficacy

Maintained efficacy is the efficacy measured at after a specified number of hours of operation. Symbol: F_M , units: lumens watts⁻¹.

3.1.10 Nadir

The angle pointing directly downward from the lamp or luminaire, or 0°.

3.1.11 New Lamp

A lamp which has not been illuminated since packaged by the lamp supplier.

Drafting note: Is this an adequate definition?

3.1.12 Power factor

Power Factor is a measure of how effectively the lamp converts the incoming electric current into useable power. The true power factor is the ratio of the real (or active) power (P) consumed in watts to the apparent power (S), drawn in volt-amperes. Unit: no unit.

$$pf = P/S$$

3.1.13 Premature Lamp Failure

In this standard, Premature Lamp Failure is defined as a lamp which fails before 1,000 hours of operation.

3.1.14 Rated average life

The time duration in hours declared by the supplier as being the rated average life of the lamp.

3.1.15 Rated colour temperature (correlated colour temperature)

The colour appearance as declared by the supplier as being the colour temperature of the lamp.

3.1.16 Rated Efficacy

The efficacy as declared by the supplier as being the efficacy of the lamp.

3.1.17 Rated frequency

The frequency or range of frequencies (in Hertz) declared by the supplier as being the frequency at which the lamp is designed to operate.

3.1.18 Rated Starting time temperature (Low temperature Starting time test)

The minimum Starting time temperature(s) as declared by the lamp supplier.

3.1.19 Rated voltage

The voltage or voltage range declared by the supplier as being the voltage or range of voltage (in Volts) on which the lamp can be operated.

3.1.20 Rated power

The wattage declared by the supplier as being the defined as real power consumed by the lamp in watts. Unit: Watts

3.1.21 Rounding

The numerical values that apply in this Standard, shall be rounded and recorded in accordance to IEC XXX , unless stated otherwise.

Drafting note: Reference to be added.

3.1.22 Run-up time

The time elapsed from when the supply voltage is switched on to when the lamp reaches 80% of the stable luminous flux. Where stable is defined as the variation in luminous flux is less than 2% per minute.

3.1.23 Self-ballasted compact fluorescent lamp

A compact fluorescent light source unit provided with single lamp cap and integral components for starting, control and stable operation that cannot be dismantled without being permanently damaged. Referred to in this part of the standard as a "lamp" or EUT.

3.1.24 Starting time

In this Standard, the Starting time time is defined as the time elapsed from when the supply voltage is switched on to when the lamp reaches a state of constant illumination. Return to previous IEC definition: "start fully and remain alight".

3.1.25 Starting temperature (Low temperature Starting time test)

The ambient temperature surrounding the lamp used in the Low Temperature Starting time test.

3.1.26 Test voltage

The voltage at which tests are carried out.

3.1.27 Test frequency

The frequency at which tests are carried out.

4 General conditions for measurement of photometric and electrical characteristics

4.1 General

Unless otherwise specified, measurements shall be made under the test conditions and with equipment conforming to Section 4.

4.2 Air movement and temperature

4.2.1 Test room

Measurements shall be taken in a room maintained at an ambient temperature of $(25 \pm 1)^\circ\text{C}$ and humidity of $\leq 65\%$ unless otherwise specified in this part of the standard. Air movement shall be in accordance with Clause 4.3.2 of CIE 121-1996.

Drafting note: Add relevant clauses from CIE.

4.2.2 Ageing room

For lamp ageing, prior to lamp life and lumen maintenance tests, the ambient temperature shall be in the range of 15°C to 40°C . Some draught is allowed but vibration and shock should be minimised.

Drafting note: More precise specification for draught may be required.

4.3 Supply

4.3.1 Test voltage and frequency

For aging and testing, the lamp shall be at the rated voltage and frequency of the lamp. If the rated voltage is a range, the lamp shall be aged and tested at the maximum voltage of the range.

4.4 Position of lamp

Unless otherwise stated for specific purposes, the lamps shall be mounted in a vertical base-up position and operated in free air for all tests including life tests.

4.5 Stabilization time

For all tests, excluding starting and run-up tests, the lamp shall not be considered stable until repeated measurements of the lamp show a variation in luminous flux of less than 2% per minute. Repeated measurements shall be taken for at least a period of 20 minutes after starting.

4.6 Lamp Aging

Unless specified elsewhere, lamp aging shall take place in the aging room for the specified number of hours of operation, according to the following cycle:

lamps shall be cycled repeatedly, such that they are on for 2 hours 45 minutes and off for 15 minutes.

Aging shall only be deemed to have occurred during the periods when the lamp is on.

5 MEASUREMENT EQUIPMENT AND ACCURACY

5.1 Test supply

The test voltage shall be within +/- 0.1% of the value specified in clause 4.3.1. The test frequency shall be within +/- 0.1% of the value specified in clause 4.3.1.

The total harmonic content in the supply voltage for the measurements, up to and including at least the 13th harmonic, shall not exceed 2% of the fundamental. The total harmonic content is determined by summation of the individual frequency r.m.s. voltages using the fundamental as 100%.

5.2 Ageing supply

The ageing voltage shall be within +/-2% of the value specified in clause 4.3.1. The ageing frequency shall be within +/- 0.1% of the value specified in clause 4.3.1.

The total harmonic content in the supply voltage for ageing, up to and including at least the 13th harmonic, shall not exceed 5% of the fundamental. The total harmonic content is determined by summation of the individual frequency r.m.s. voltages using the fundamental as 100%.

5.3 Power measurement

Measurements of power shall be made with a suitably calibrated wattmeter or power analyzer with an uncertainty of less than or equal to 0.8%. The power measurement instrument shall have the following characteristics:

Bandwidth: 500KHz

Response time: 0.05 seconds

Accuracy: 0.05% for measurement of voltage and current

5.4 Luminous flux measurement

5.4.1 Measurement equipment for tests

All measurement equipment shall be traced to a national/international laboratory standard.

5.4.1.1 Integrating Sphere

An integrating sphere of the following dimensions shall be used for the starting and run up tests:

For lamps where the largest dimension $\geq 400\text{mm}$, the sphere shall have a diameter of at least 2.4 m.

For lamps where the largest dimension $<400\text{mm}$, the sphere shall have a diameter > 6 times that dimension.

The internal surface of the sphere shall be coated with diffuse non-selective paint in accordance with CIE 84.

The lampholder and supports should be as small as possible and preferably highly reflective. The sphere shall have as small a screen as possible to shield the photometer head from direct illumination, and be positioned between the centrally located light source and the photometer head port, at a distance 1/3 to 2/3 times the sphere radius from the photometer head port.

Drafting note: More exact specifications may be required the term 'as small as possible' in the above sentence.

5.4.1.2 Goniophotometer (Distribution Photometer)

The photometer should be designed so the test lamp can be correctly mounted in relation to the photometer optical axes. The photometer must also be capable of determining luminous

intensity and necessary angular settings in the test planes of the lamp. In all cases the mounting apparatus should not interfere with light emitted by the lamp.

The distance from the lamp to photometer port is at least 6 times the largest dimension of the tested lamp.

Angular settings shall be reproducible within +/- 1/4 degree.

5.4.1.3 Spectroradiometer

The accuracy of the spectroradiometer shall be better than +/- 0.2 nm over the visible spectrum (380-780nm), and it shall have a wavelength repeatability: 0.1nm and stray light characteristics of 10^{-5} .

5.5 Time measurement

Measurements of event time shall be made with an overall uncertainty of ± 1 % or better.

5.6 Mercury content measurement

Refer to. ANNEX A.

6 Test Procedures

6.1 Starting Time Test

The Starting Time Test is to be conducted on new lamps.

6.1.1 Test conditions

The test voltage for the starting test shall be equal to rated lamp voltage less 10%. In the case where the lamp is rated for a range of voltages, the test voltage shall be 10% less than the lowest value.

The test setup and equipment shall be as shown in Figure 3.

Figure 3: Set up for Starting time test, Method B

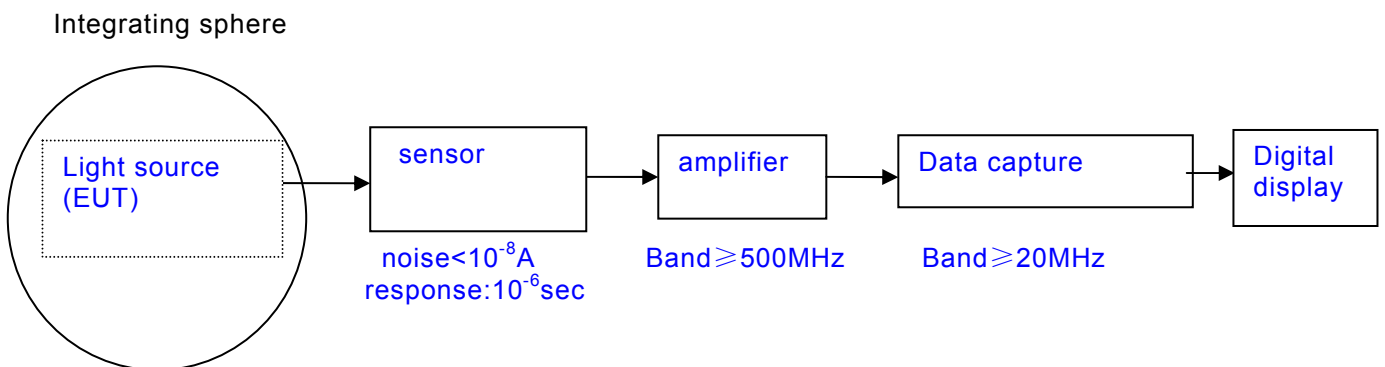

6.1.2 Test Procedure

- 1) The equipments shall be set up as in Figure 3.
- 2) The equipment shall be left to stabilise in the test room for a period of 30 minutes prior to commencement of the test.
- 3) Switch on power to measuring device(s).
- 4) Switch on power to the EUT.
- 5) The test shall run until the lamp is constantly illuminated. If after a reasonable period the lamp does not illuminate, cease the test.
- 6) Record luminous flux and time measurements taken during the test, and details of ambient conditions.

6.1.3 Calculations:

The Starting time is determined as:

The time from switching on to the when the lumen output reached the lowest point of the last trough prior to maximum light output (see Figure 4). If no troughs are discernable, the starting time shall be the time when luminous flux increases (see Figure 5).

Revision idea (Proposed by China National Light Testing Centre)

The Starting time is determined as:

The time from switching on to the when the lumen output reached the first peak point after which the light output is continual (see Figure 4 for there are pulses before the continual light output, or Figure 5 for there are no pulses before the stable light output).

Figure 4: Diagram for calculation of Starting time time, Method B (pulses)

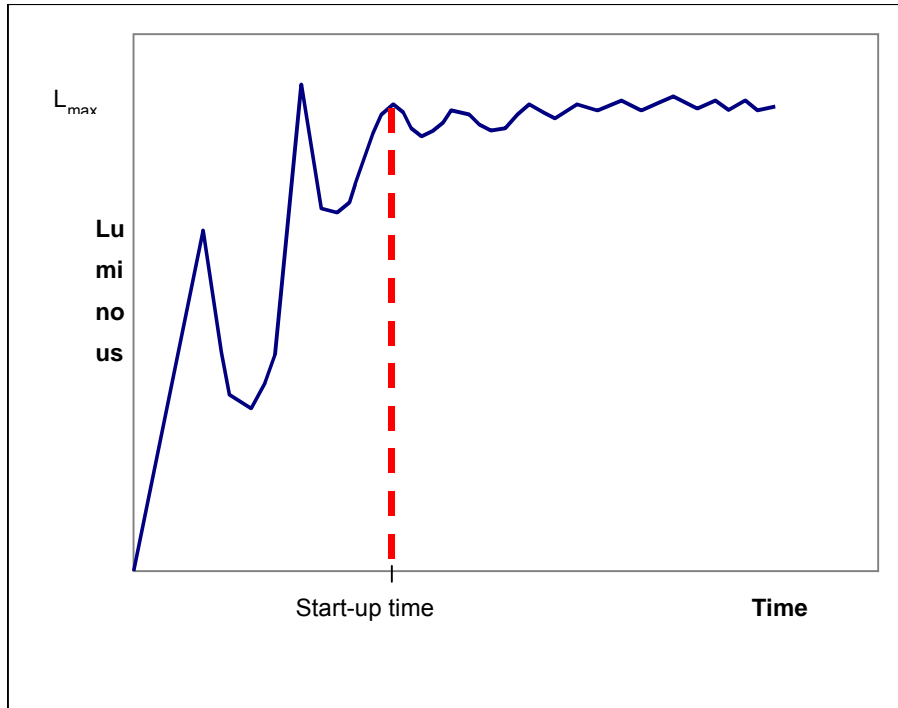

Figure 5: Diagram for calculation of Starting time time, Method B (no pulses)

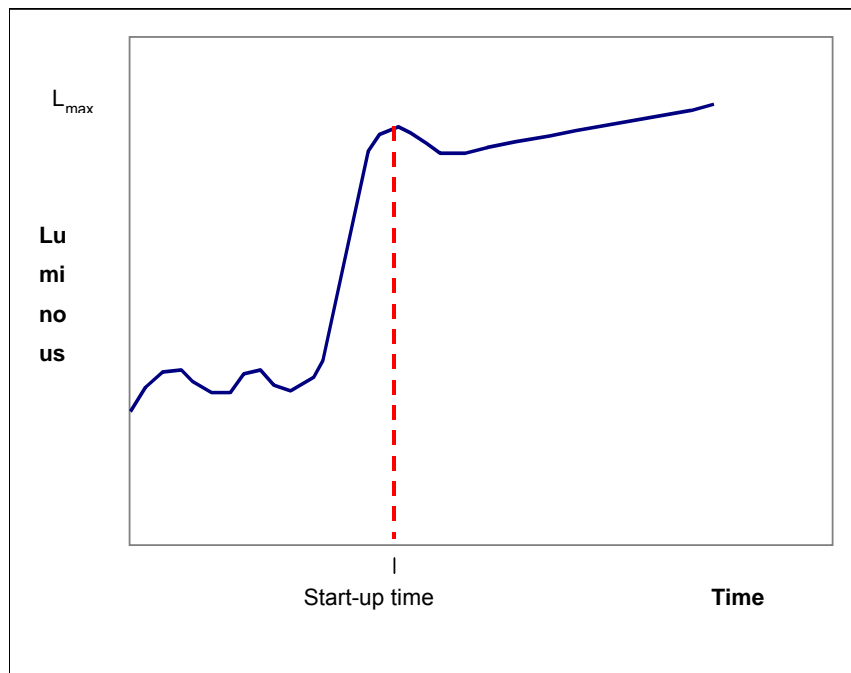

Figure 4: Diagram for calculation of Starting time time, Method B (troughs)

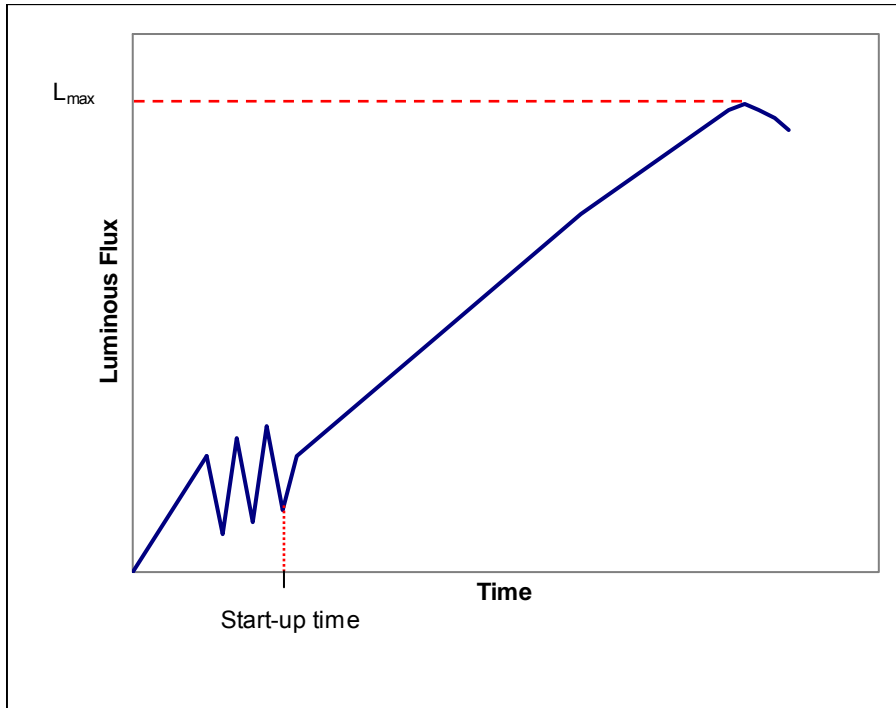
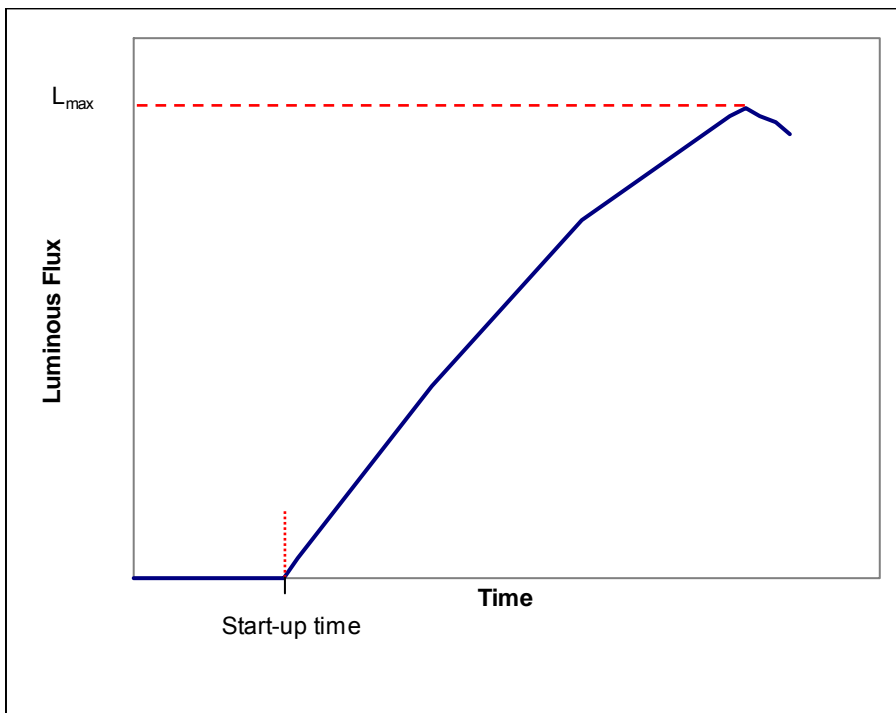

Figure 5: Diagram for calculation of Starting time time, Method B (no troughs)



6.2 Run-up Test

The Run-up Test is to be conducted on lamps aged for 100 hours.

6.2.1 Test Conditions

The test voltage for the Run-up test shall be equal to rated lamp voltage. In the case where the lamp is rated for a range of voltages, the test voltage shall be the lowest value.

The test setup and equipment shall be as shown in Figure 6.

Figure 6: Test set-up for Run-up test

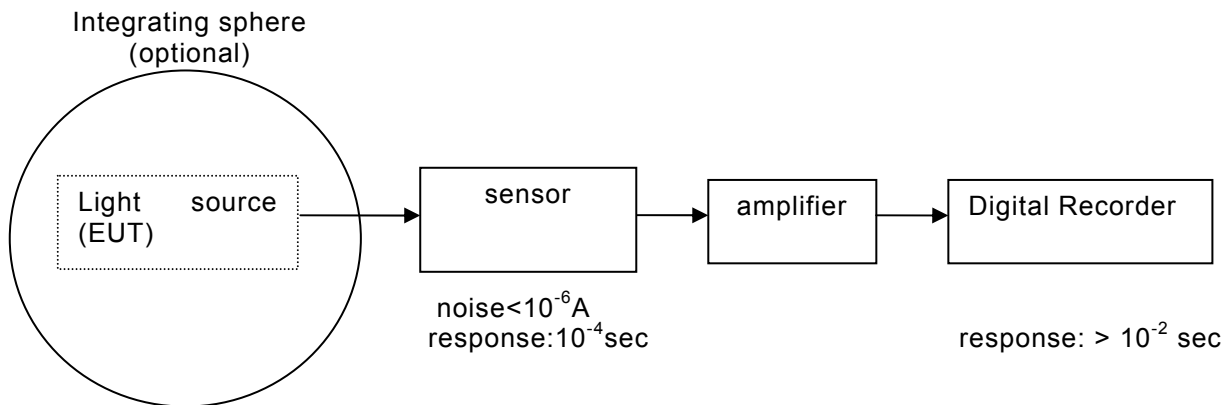

6.2.2 Test Procedure

- 1) The equipments shall be set up as in Figure 3.
- 2) After aging the lamp shall be left for at least 24 hours in the aging room before being moved to the test room.
- 3) The equipment shall be left to stabilise in the test room for a period of 30 minutes prior to commencement of the test.
- 4) Switch on power to measuring device(s).
- 5) Switch on power to the EUT.
- 6) The test shall run until the lamp output is considered stable or 20 minutes, whichever is shorter. Where stable is defined as the variation in luminous flux is less than 2% per minute.
- 7) Record luminous flux and time measurements taken during the test, and details of ambient conditions.

6.3 Calculations:

The Run-up time is calculated as the time taken to achieve 80% of the stable light output, or maximum light output within 20 minutes from the start of the test.

The time taken from the commencement of the test to a point where the variation in luminous flux of the lamp is less than 2% per minute shall be assumed to be the time taken to achieve stability.

Where the lamp does not achieve stability, the maximum lumens output within the 20 minute test period shall be used to calculate the Run-up time.

6.4 Low Temperature Starting Time Test

The Low-temperature Starting Time Test shall be conducted using new lamps.

6.4.1 Test Conditions

The test voltage for the Starting Test shall be equal to rated lamp voltage less 10%. In the case where the lamp is rated for a range of voltages, the test voltage shall be 10% less than the lowest value.

The lamp shall be placed in a cooling cabinet with a window to allow visual inspection. The cabinet shall be maintained a stable temperature, as specified elsewhere, within $\pm 1^{\circ}$ K of the specified temperature.

Photometric measuring equipment is not required for this test.

6.4.2 Test Procedure

- 1) The EUT shall be switched on and a stopwatch used to record the time when the lamp achieves constant illumination.
- 2) The ability of the lamp to start at the specified temperature shall be confirmed by visual inspection.
- 3) If the lamp fails to illuminate within 30 seconds, cease the test.

6.5 Initial Efficacy Test

6.5.1 Test Conditions

The Initial Efficacy test shall be conducted using lamps aged for 100 hours.

The test voltage shall be equal to the rated voltage, except where the lamp is rated at a voltage range, in which case the mid-point voltage shall be used.

Luminous flux shall be measured using one of the methods in CIE Publication 84. Electrical connections to the lamp shall be as described in CIE Publication 84.

Drafting note: add specific clause.

Revision idea (Proposed by China National Light Testing Centre)

6.5 Initial Efficacy Test

6.5.1 Luminous flux test procedure

6.5.1.1 Preburning

Prior to taking initial measurements, the lamps must be seasoned 100h. Before any measurements are taken, lamps shall be operated long enough to reach stabilization and temperature equilibrium.

Seasoning, preburning, and photometric measurements shall all be done with the lamp in the same orientation. The orientation should be based up unless other specified.

6.5.1.2 Method of luminous flux, color and luminous intensity distribution measurements

a. Circuit

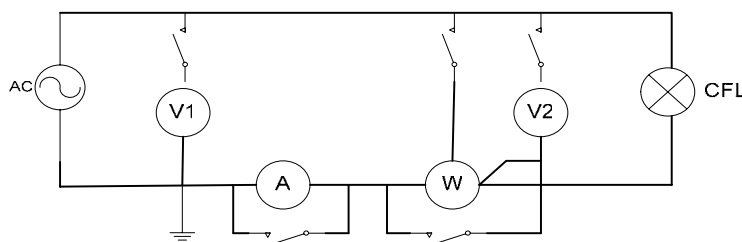

b. Transfer of lamp to the measurement circuit

Because of the time required for preburning, it is usually desirable to preburn lamps at a separate location from the photometric equipment, thus freeing up test equipment for measurements of other lamps. In this case, the test lamp is extinguished at the end of the preburning period and then transferred to the test position. As it is moved from one location to the other, it is important to minimize the time for transferring and keep the test lamp in the same physical orientation as maintained during preburning.

c. Stabilization

Once preburning is complete and the lamps have been transferred to the test position, the lamps shall be burned long enough to obtain restabilization and temperature equilibrium. A period of 15 minutes continuous burning is usually sufficient. However, the better method of judging the stabilization of a lamp is to check the light output

periodically. When the light output of the lamp is stable, the lamp is then considered stable.

The lamps should be confirmed stable before photometric measurements.

d. Electrical settings

Input voltage/input wattage /input current should be controlled and the test lamp should have been stabilized before taking the test. If input voltage is controlled, the test voltage should equal to the rated voltage. If the rated voltage is a range, the test should be taken at the maximum and the minimum values of the range respectively. All of the conditions controlled must be represented in the report.

6.5.1.3 Luminous flux measurement (two methods)

a. Integrating sphere measurement (two methods)

1. Distribution photometry

Luminous flux (lm) can be obtained from total spectrum radiant flux (absolute unit). Luminous flux of test source, represented by F_t , is calculated by:

$$F_t = K_m \int_{380}^{780} F_s(\lambda) V(\lambda) d\lambda$$

Where, $V(\lambda)$ represents spectral luminous efficiency;

K_m represents the maximum luminous efficacy, 683lm/W;

$F_s(\lambda)$ represents the total spectral radiant flux of the test source.

2. Integrating method

A standard source whose spectral energy distribution is similar to that of the source to be measured should be used in the test.

Calculating formula is:

$$F_t = (I_t / I_s) \cdot F_s \cdot K \cdot \alpha$$

Where,

F_t, F_s Represent the luminous flux of the test source and the standard source respectively;

I_t, I_s Represent the photocurrent of the test source and the standard source respectively;

If the spectral energy distribution of the test source differs from that of the standard source, color correction must be taken.

K – coefficient of color correction;

$$K = \frac{\int P_t(\lambda) V(\lambda) d\lambda}{\int P_s(\lambda) V(\lambda) d\lambda} \cdot \frac{\int P_s(\lambda) \rho(\lambda) \cdot S(\lambda) d\lambda}{\int P_t(\lambda) \rho(\lambda) \cdot S(\lambda) d\lambda}$$

$$\rho(\lambda) = t(\lambda) \cdot \frac{\rho'(\lambda)}{1 - \rho'(\lambda)}$$

Where,

$P_t(\lambda), P_s(\lambda)$ represent the relative spectral power distribution of the test source and the standard source respectively;

$V(\lambda)$ represents spectral luminous efficiency;

$\rho(\lambda)$ Represents the spectral reflectivity of the sphere wall;

$t(\lambda)$ Represents the spectral transmissivity of the window glass of the integrating sphere;

$S(\lambda)$ Represents the relative spectral sensitivity of detector.

Note: When using integrating method, both distribution photometry and integrating method need appropriate corrections unless the standard lamp agree in physical size and shape with the lamps under test. When the test lamps and the standard source are not of the same size and shape, absorption correction shall be made. The reflectivity of the

lamp's holder, detector and other things should be considered. Absorption correction is as follow:

$$F_c = F_t \times \alpha$$

where, F_t represents the luminous flux measured;

α represents the coefficient of absorption correction;

F_c represents the final result after absorption correction.

b. Goniophotometer (Distribution Photometer)

1. Precaution should be taken to avoid rolling or shaking of the lamp to keep its output stabilization. The goniophotometer should be a device consists a photodetector (or a mirror which will reflect the light to the photodetector) that moves on a rotating boom or arc shaped track on a vertical plane, or some other devices that meet the needs.

2. Test procedure:

a) Lamp Mounting

The light center of the test lamp, that is, the geometric center of all discharge tubes should be mounted at the center of the goniophotometer.

The original orientation of the lamp should be selected so that the vertical plane passing the two cathodes is parallel to the 0-degree test plane.

A sketch shall be drawn to indicate the lamp's center and the lamp's original orientation corresponding to the goniophotometer.

b) Angles and Planes for Measurement

Vertical angle range shall be from nadir (0 degree) to zenith (180 degree). The vertical angle spaces should be no more than 10 degrees.

Readings should be taken in at least 36 vertical half-planes. That is the horizontal angle spaces should be no more than 10 degrees. The horizontal angles should be counter-clockwise arranged when looking down at the lamp.

Angle spaces may be reduced when better accuracy to be obtained or when the light distribution uniformity is worse.

c) Stray Light Measurement

Stray light data should be measured and recorded.

d) Data Processing

The test distance that is the distance covered by the light transmitted from the goniophotometer center to the detector should be recorded.

The stray light data should be correspondingly subtracted from the original ones. The total lumens of the lamp should be calculated from the latter results.

d1. Computing the Total Lumens

Computing the total lumens may be based on the following formula:

$$F_t = \int_0^\pi \int_0^{2\pi} E(\theta, \varphi) R^2 \sin \theta d\theta d\varphi$$

where:

F_t : total lumens of the test lamp

$E(\theta, \varphi)$: illuminance value of the spot that indicated by the horizontal angle φ and the vertical angle θ

θ : vertical angle

φ : horizontal angle

R: test distance

d2. Draw Luminous Intensity Distribution Curves

The angle of the plane that contains maximum luminous intensity value spot should be found out and be recorded as φ_{\max} .

The luminous intensity distribution curves of three typical planes: 0-180 degree plane, 90-270 degree plane and the plane that contains φ_{\max} , should be drawn in one figure. The curves should be distinguished from each other. Clear indication of them should be given. Different colors or forms may be used. Polar coordinate is commended to be used to draw the curves: vertical downward as polar axis, vertical angles as polar angles, and the candela values as the polar distances.

c. Measurement of high ambient temperatures required lamps

The ambient conditions should be satisfied when testing the lamps that designed to operate in high ambient temperatures.

The preferred method is to compare the lamp to an incandescent reference flux standard within an integrating sphere or upon a goniophotometer. Where this method is used a colour correction factor shall be applied.

These tests shall be made with sensor which has the following characteristics:

Deviation of the relative spectral responsivity from the $V(\lambda)$ function (f_1) shall be +/- 1.5.

UV (u) and IR (r) response of less than 0.2%.

Linearity error (f_3) of less than 0.2%.

Cosine correction $f_2=1.0\%$

6.5.2 Test Procedure

- 1) The lamp and equipment shall be left in the test room to stabilise for at least 30 minutes prior to the test commencing.
- 2) The lamp shall then be properly mounted inside the sphere, and measurement equipment and the lamp switched on.
- 3) Maintain the temperature around the lamp in accordance with Clause 4.2.1.
- 4) Stabilisation shall be monitored by performing repeated measurements and ensuring that the values do not show a trend in any particular direction.
- 5) After stabilisation, measurements of luminous flux and lamp power shall be taken at the same time, and recorded.

6.5.3 Calculations

Initial efficacy is calculated as follows:

$$\frac{\text{lumen flux}}{\text{lamp power}} \quad \text{Units: lm/w}$$

6.6 Lumen Maintenance and Maintained Efficacy Tests

The sample of lamps that underwent initial efficacy tests shall be aged in the aging room as described in Clause 4.6 for the specified number of hours.

Unless specified elsewhere, the lumen maintenance test shall be undertaken after 2,000 hours of operation. Maintained efficacy shall then be calculated using the same procedure as 6.5 above.

Further lumen maintenance tests may be performed as required, in increments of approximately 1000 hours. One of these tests may be performed at the manufacturer's rated average lamp life.

The test conditions and equipment shall be as described in Section 4, 5 and 6.5. The test procedure shall be as described in clause 6.5.

6.7 Lamp Life Test

The sample of lamps shall continue to age after the maintained efficacy test in the aging room, according to the switching cycle in section 4.6. The hours of operation shall be recorded for each lamp, until lamp failure as defined in 3.1.9. This is may be determined by inspection, photo-sensors or by a separate lumen maintenance test.

Recorded hours of operation shall only include the periods when the lamp was on. Hours of operation shall include the initial aging period.

The test conditions shall be as described in Section 4, 5 and 6.5.

6.8 Switching Withstand Test

The Switching Withstand test shall be conducted on lamps aged for 100 hours, and under the conditions specified for the Lamp Life test.

The switching cycle used for the Switching Withstand test shall be 10 sec on, 5 minutes 50 sec off.

Drafting note: The following options for the number of cycles used in the withstand test are proposed.

This shall be maintained for:

Option 1: 12,000 cycles.

Option 2: A number of cycles equivalent to twice the value of the rated lamp life expressed in hours.

If the lamp fails to illuminate during the test period, the lamp is deemed to have failed the test

6.9 Test for Colour Appearance and Rendering Index

The chromaticity co-ordinates (Correlated colour temperature) and colour rendering index (CRI) shall be performed on lamps aged for 100 hours. The chromaticity co-ordinates shall be measured with a spectroradiometer in accordance with CIE 63:1984.

Revision idea (Proposed by China National Light Testing Centre)

6.9 Colorimetric measurements

The spectral measurement method is often used in color measurement, and the equipment used is spectroradiometer. Calculating is based on the method of CIE colorimetric system.

6.9.1 While testing, it should be noted that the beam of the standard source and that of the test source should get into the spectrometer under the same geometry conditions. And the beams should irradiate the incident slit completely and uniformly.

6.9.2 If there is a diffuse baffle-board between light source and the spectrometer, the beam of the light source should irradiate the diffuse baffle-board perpendicularly. and then the beam ,between which and the normal is a 45° angle, get into the spectrometer directly or through optic systems.

6.10 Light Distribution Test

The Light Distribution test shall be performed on lamps aged for 100 hours.

The test voltage shall be equal to the rated voltage, except where the lamp is rated at a voltage range, in which case the mid-point voltage shall be used.

After stabilisation, the Nadir measurement shall be taken with a goniophotometer, and enough values at 90 degrees from the Nadir to determine an average of the 90 degree plane.

The light distribution ratio is calculated as:

The light intensity at Nadir

The average of light intensities at 90 degrees to Nadir

6.11 Power Factor Test

The Power Factor test shall be performed on lamps aged for 100 hours.

The lamp shall be set-up in accordance with Section 4 and 5, and the power factor calculated.

6.12 Test for Electromagnetic Compatibility (EMC)

Refer to appropriate part of IEC 61000

Drafting note: It is intended that reference will be made to tests for harmonics in IEC 61000, however further comments are invited on whether other EMC tests should be included

6.13 Mercury Content Test

Tests for mercury content of lamps shall be carried out on a separate sample of lamps in accordance ANNEX A.

7 Sample Sizes for Tests

The minimum number of samples used for each test shall be as follows:

Starting Time:	10
Run-up:	10
Initial Efficacy:	10
Lumen maintenance:	10
Lifetime:	10
Switching Withstand:	6
Colour:	10
Cold Start	6
Light Distribution	6

8 Marking Requirements

Where a CFL is marked with a performance mark, the mark shall be as indicated in ANNEX B.

NOTE: The performance mark is not a label providing information on the energy performance of the lamp to consumers.

Drafting note: These marking requirements have been included to facilitate adequate time for comment, pending agreement on whether a marking system would be beneficial

9 TEST REPORT

See ANNEX C

Annex A

(normative)

Method for Determining the Mercury Content in lamps

A.1 GENERAL

A.1.1 SCOPE

This standard specifies a method of test to determine the quantity of mercury (Hg) present in any type of fluorescent lamp, excluding mercury present in the vapour state.

This test method specifies the procedures which can be used to determine accurately the mercury content of any type of fluorescent lamp in which mercury has been introduced as the carrying agent for the discharge between the electrodes.

The method involves the chemical digestion of the mercury contained within a lamp and the determination of that mercury content on a per lamp basis. This is achieved using a method of solubilisation of the entire mercury content contained within the tube using acidic digestion methods and the accurate determination of that mercury content using standard mercury solutions to determine that mercury content. This will allow comparison between the mercury content of different lamps and with internationally accepted standards set for lamp mercury content.

A.2 DEFINITIONS

For the purpose of the standard the following definitions apply.

A.2.1

Fluorescent Lamp

A discharge lamp of the low pressure type, in which most of the light is emitted by one of several layers of phosphors excited by the ultra-violet radiation from the discharge from the electrodes.

A.2.2

Double capped fluorescent lamp

Fluorescent lamp having two separate caps and mostly of tubular form and linear shape.

A.2.3

Single capped fluorescent lamp

Fluorescent lamp with a single type cap but with the discharge tube bent or formed into a spiral or convoluted tube. These may or may not contain Mercury as amalgams.

A.2.4

Discharge electrodes

Discharge electrodes are located in the lamp caps and may be of simple tungsten wire design, or may comprise a grid or container in which a mercury amalgam is present.

A.2.5

Mercury and amalgams

Mercury in fluorescent lamps is generally free mercury or mercury vapour under discharge which provides the conducting agent between the electrodes. Mercury in fluorescent lamps may exist in three possible states as followed:

- 1) Vapour in a lamp
- 2) Liquid metal or in an oxidised state.
- 3) An amalgam of mercury with another metal such as Titanium (Ti), or Bismuth (Bi).

This test method determines the total amount of mercury present as either liquid metal, or oxidised state, or in an amalgam. Mercury in the vapour state is not determined but represents only a very minor fraction of any mercury and can for all practical purposes be ignored in the determination.

A.2.6

Lamp samples

A minimum of three samples of the same model lamp, selected from the same manufacturer's batch, should be used to determine the mercury content of the lamp model.

In order to select the correct digestion procedure(s), it must be determined prior to the start of the analysis whether the lamp contains a mercury amalgam.

A.2.7

Measurement equipment

The equipment used for preparing and measuring the sample for determination of mercury.

A.2.8

ICP-OES

An inductively coupled plasma optical emission spectrophotometer used for the determination and calculation of the mercury content of the final sample.

A.3 GENERAL TEST PROCEDURE

Test conditions are set up to determine the mercury content in a series of at least three lamps of the same type by breaking the lamp itself under controlled and captive conditions (Method 1) or breaking the vacuum seal of the lamp to allow the interior contents to be accessed (Method 2).

The method and procedures described in this document are to take place in a controlled environment of a chemical laboratory. All safety precautions shall be used for the protection of the laboratory analyst from the lamps, the destruction of the lamps and the mercury and any other phosphor content of the lamps. The procedures must be carried out in the safety of a chemical laboratory equipped for the handling of hot acids, mercury and glass materials using the appropriate fume cupboards and other hazard protection equipment. All materials are to be disposed of using proper disposal procedures for these types of wastes including mercury wastes.

The total mercury in the lamp is determined by dissolving the entire mercury content in any of its forms in a suitable acid mixture to ensure all mercury is entirely dissolved from the interior contents of the lamp.

The method then measures the mercury in the dissolved acid mixture taking account of the actual volume of acid used in the determination and measurement of the mercury in the acid samples using the methods of inductively coupled plasma with optical emission spectra measured in the spectrophotometer (ICP-OES). The mercury readings from the emission spectra are then calculated against known prepared mercury standard solutions to calculate the actual mercury content for each lamp or batch of lamps.

A.4 MEASUREMENT EQUIPMENT

A.4.1 PREPARATION EQUIPMENT REQUIRED – METHOD 1

Pliers and sharp knife

Beakers, volumetric flasks, measuring cylinders

Disposable 3ml plastic transfer pipettes

Putty or plasticine or similar

Automatic pipettors to dispense specific volumes and disposable tips

0.45 micron filters suitable for acid solutions of up to 200 ml.

Glass scoring file, heating wire and heater, hammer

Electric hot plate suitable for heating the acid in the bulb itself, or beaker

Safety gloves (teflon type)

Acid protective equipment, gloves and safety glasses, lab coat.

A.4.2 REAGENTS- METHOD 1

Nitric acid, HNO_3 , concentrated, 70%

Water: High Grade Distilled water or Milli Q.

Dilute Nitric acid (1+1): Equal volumes of nitric acid, 70% and water. The nitric acid shall be added to the water and mixed. Caution: A high amount of heat transfer occurs during mixing. Always add acid to water.

Standard solution of mercury salts ie 1000mg per litre mercuric nitrate purchased from an appropriate supplier.

Diluted standard solutions, standard mercury solution diluted in deionised water. Mercury standard solution should be diluted on the day of measurement.

A.4.3 ADDITIONAL EQUIPMENT FOR METHOD 2

Round-bottomed flask of type suitable for reflux procedures, which includes one glass stoppered side arm

Reflux condenser

Electric heating mantle for round-bottomed flask for refluxing

A.4.4 ADDITIONAL REAGENTS FOR METHOD 2

Hydrochloric acid, HCl , concentrated, 37%

Aqua regia: concentrated nitric acid is mixed with three times the volume of concentrated hydrochloric acid. Use caution when making this solution.

Sulphuric acid, H_2SO_4 , 98%

Sulphuric acid (1+1): Equal volumes of sulphuric acid and water. Caution: A high amount of heat transfer occurs during mixing. Always add acid to water.

NOTE: All chemicals must be high quality analytical reagent (AR) grade

A.4.5 INSTRUMENTS

Inductively Coupled Plasma -Optical Emission Spectrometer (ICP-OES):

The instrument which gives light emission intensity with suitable sensitivity and stability in the directed measurement and concentration range for detection of the mercury emission spectra. Refer to the specific operating manuals for such instruments. Suitable instruments are manufactured by a number of manufacturers and are available in suitably equipped inorganic chemistry laboratories.

Gas:

High quality pure, inert Argon gas, is used as the principle carrying gas for the plasma torch of the instrument.

An example of the principle of an ICP-OES is shown in Fig. A1.

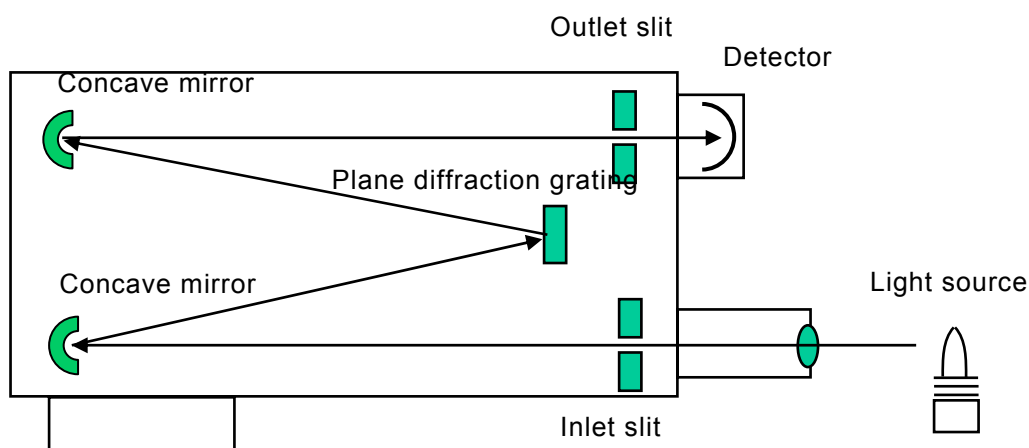

Fig.A1 Spectrophotometry part using sequential type spectroscope (an example)

A.5 TEST SETUP

A.5.1 LAMPS

The test of lamps is setup by obtaining a selection of lamps that are required to be tested. These should be cleared labelled as samples for test and require a minimum of three lamps of identical type and markings from the same manufacturing run. Groups or batches of lamps separately labelled may be tested in parallel provided all samples are separately coded and recorded throughout the determination procedure.

A.5.2 LABORATORY

A suitably equipped inorganic chemical laboratory with separate wet chemistry preparation areas is required. Mercury preparations and acids shall be handled in an acid-suitable, fume cupboard. Preparation areas and safety equipment maintained according to relevant standards.

Lamps shall not be broken or treated in a laboratory where other mercury determinations are being made. All lamp handling and acid preparation procedures must be carried out in a separate preparation laboratory to the measuring equipment, and equipped with a suitable fume cupboard.

Proper procedures for disposal of all materials, glass, metal and acids shall be available at the laboratory location.

A.5.3 SAMPLE SETUP

A.5.3.1 Labelling

All lamps to be tested shall be labelled and all manufacturer's marks recorded onto separate test sheets clearly identifying each lamp sample.

All beakers, flasks, plastic containers or bags used for holding acid digestions for determination shall be separately labelled and recorded on test sheets.

A.5.3.2 Acids

All acids required, dilutions or mixtures of acids shall be prepared in the fume cupboard and separately labelled and recorded.

A.5.3.3 Standard solutions

All standard solutions required for measurement and determination of concentration shall be separately prepared and recorded in standards test sheet records.

A.5.3.4 Preparation equipment

All minor equipment, glassware and plastic equipment and heating equipment shall be collected, prepared and tested to ensure its reliability, accuracy and functionality.

All measuring equipment used, volumetric flasks, pipettes, dilution equipment, pipettors shall be checked to ensure that they are delivering correct volumes and amounts as required in the procedure.

A.5.4 MEASURING EQUIPMENT SETUP

The ICP-OES used for measuring the concentration of mercury in the final sample solutions shall be separately maintained according to the manufacturer's specifications. The daily maintenance checks and records of the instrument's performance in measuring the various elements will normally be a routine procedure of the laboratory measuring the elements. These routine laboratory quality procedures are to be followed and the instrument checked for accuracy and reliability of measurement for the mercury emission spectra using the standard procedures in place for the ICP-OES instrument.

Appropriate procedures for the automatic sampling equipment and argon gas supplies are also to be checked according to routine daily laboratory procedures.

A.6 TEST PROCEDURES

Two test methods are described below:

Method A or Method B may be used for fluorescent lamps not containing mercury in amalgam form.

Method B shall be for fluorescent lamps containing mercury in amalgam form.

A.6.1 METHOD A: MERCURY DECOMPOSITION IN A LAMP BULB NOT CONTAINING AMALGAMS

The metal caps of the fluorescent tubes shall be removed. This may be done by twisting off the caps with pliers while holding the tube wrapped in paper towel to prevent glass injury. This will break the cement holding the caps and the wires.

At one end of the tube, break the small central inner glass tube used to evacuate the tube. This may be done using pliers.

Introduce the required amount of diluted nitric acid into the lamp using a 3ml plastic transfer pipette. Acid shall be introduced in 3ml lots while rotating the tube so that the phosphor is washed off the inside of the tube.

Once the required amount of acid is introduced, the broken end of the evacuation tube shall be plugged with a small amount of putty, plasticine or similar, and the tube inverted several times to wash the insides of the tube and filaments so that all phosphor is removed.

The lamp shall then be placed vertically into the preheated hot plate designed for the purpose and maintained at between 80°C to 100°C for 50 minutes. The tube shall be inverted every 10 to 15 minutes to ensure that the filament parts at the top end of the lamp are washed in hot nitric acid.

Following (e), hold the lamp over a beaker and again carefully break the evacuation tube at the other bottom end of the tube with pliers and allow the solution to run into a beaker.

Introduce another 20 ml of diluted nitric acid into the lamp through the upper evacuation tube while holding over the beaker, rotating the tube to ensure all the inside is washed. Hold the tube horizontally and rotate carefully then allow the solution to run into the beaker. Wash the tube with a further 20 ml of water ensuring that all parts of the tube is washed thoroughly. Collect all washes. The final volume should be less than 200 ml.

The final solution shall be filtered through a 0.45 micron filter into a volumetric flask. Water shall be added to make up a total volume of 200 ml.

This solution is then diluted as required and appropriate samples analysed using ICP-OES. The analysis must include a minimum of three samples of any light bulb batch as well as the blanks and standards.

A.6.2 METHOD B: MERCURY DECOMPOSITION IN A LAMP BULB CONTAINING AMALGAMS.

Remove the plastic base and base cement completely with a knife, or pliers from the bulb.

Score the bulb with an appropriate glass scoring file on or near the end of the tube with a file.

Heat a glass rod or Nickel/Chromium wire to red heat and touch the score line to crack the bulb and allow the lamp bulb leak to atmospheric pressure.

Take out the amalgams from the inside of the tube and dissolve them in accordance with the method given below.

Wet all of inside of the bulb with water in order to prevent losing mercury contained in the dry phosphor coating when the bulb is broken into pieces. Collect the water in a beaker.

Put the bulb into a thick plastic bag and break it by hitting the bulb from outside the plastic bag with a hammer or heavy object (see figure A2), or break the bulb inside a beaker, jar or similar container depending on the size of the bulb with pincers or pliers. (In order to prevent the plastic bag from being cut, pincers or pliers can be used to break up into smaller pieces).

Note: An alternative method that can be used is to use a suitable glass or plastic flask or other lidded container in which to break the pieces, then smashing the contents further with a large porcelain or glass ball (toy marble).

In either case, with a plastic bag or flask it is intended to minimise injury to the operator as well as contain all pieces of glass. Ensure complete digestion of all the contents.

Tip all the pieces from the bag into a beaker and rinse inside the plastic bag or container with known amount of water.

Make up the volume of solution in the beaker containing water with concentrated nitric acid to be a 1+1 concentration (about 30 ml). Stir or wash the pieces around the container with a glass rod until no more phosphor comes off from the pieces of glass. Heat the beaker on a hot plate and keep at about 80 °C for 50 minutes.

Cool the solution to room temperature. Filter through a 0.45 micron filter. Transfer the filtrate and filter washings into a volumetric flask and water added to make up to an appropriate volume⁽¹⁾⁽²⁾⁽³⁾.

Notes

⁽¹⁾This sample solution can be stored for a week, however diluted test solutions should be measured on the same day.

⁽²⁾The amount of diluent depends on the size and shape of the lamp, since the mercury content of the lamp tube with the amalgam removed from the lamp may be very small, the amount of diluent should be small as possible.

⁽³⁾ In the case of a lamp containing an amalgam do not make up to final volume until the solution from Section 6.2.1 or 6.2.3 is added to the flask.

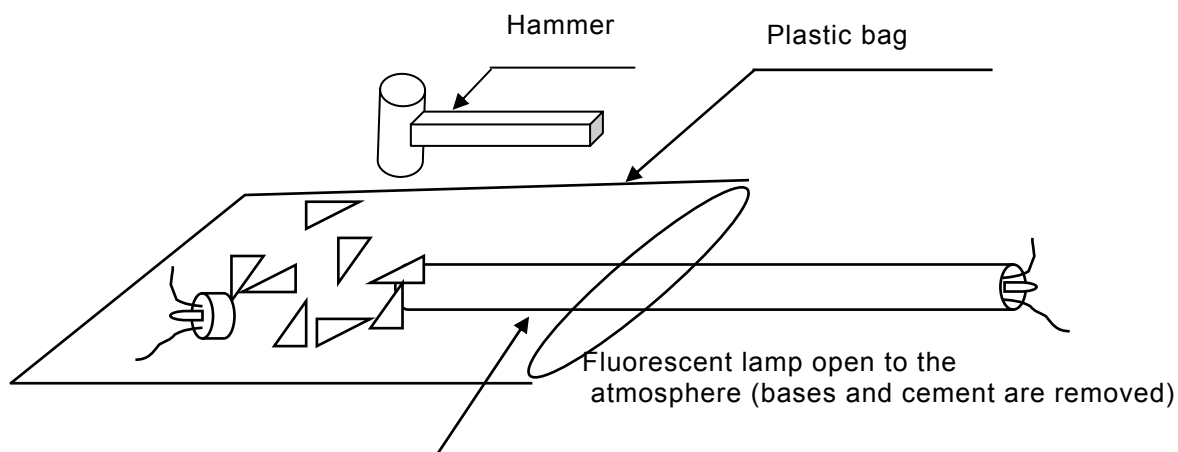

Fig. A2 Method of lamp destruction using the plastic bag method.

A.6.2.1 Decomposition of mercury amalgams: Titanium amalgam

An example of a titanium amalgam contained in a fluorescent lamp is shown in Fig.A3

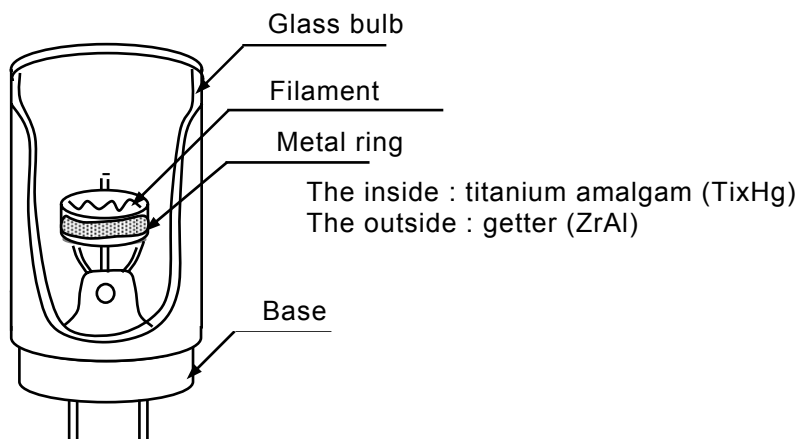

Fig.A3 Example of titanium amalgam in a fluorescent lamp electrode

Take amalgam with metal ring from inside of a lamp after using procedure described in the previous section and put it in a round-bottomed flask.

Connect a reflux condenser to the round-bottomed flask, place into a heating mantle which is placed in a fume cupboard. Ensure that the cooling water is flowing through the condenser.

Add 10ml of dilute sulphuric acid (1+1) through the side arm and heat gently for about 30 minutes.

Add 5 ml of dilute nitric acid (1+1) through the side arm and heat until white fumes are observed.

Add 5 ml of dilute nitric acid (1+1) through the side arm and heat until any salts which have formed have completely dissolved.

Cool the contents and proceed to filter and make up in a volumetric flask to a known volume as previously described. Record all final volumes on the test sheets.

If the amalgam is within a bulb, add this filtered solution to that of the solution in the volumetric flask from A6.2 J.

A.6.2.2 For other types of amalgam pellet and amalgam mesh containing lamps

An example of amalgam pellets and amalgam mesh contained in a fluorescent lamp are shown in Fig.A4

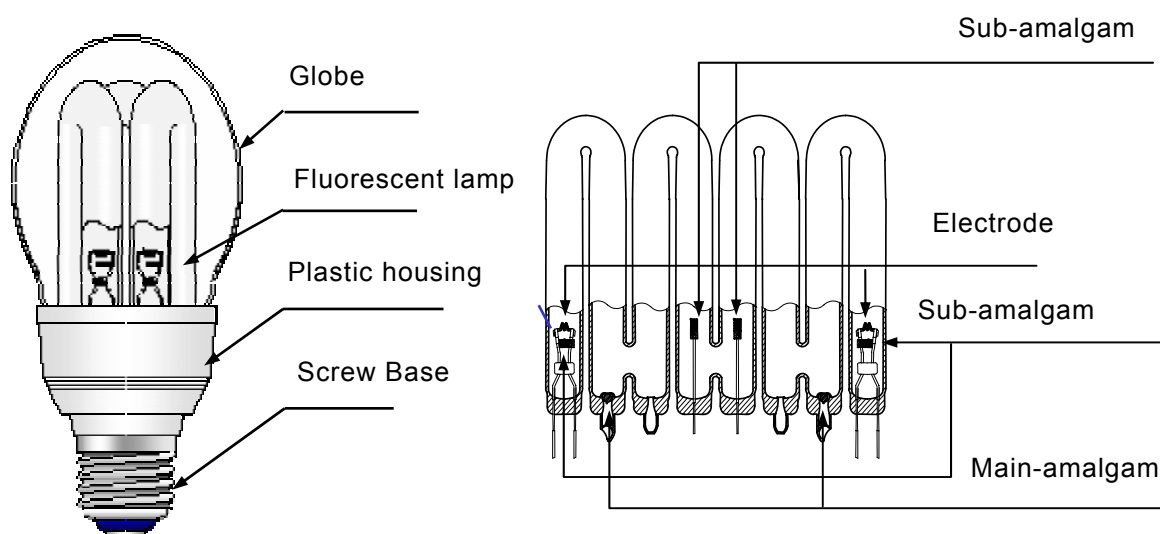

Fig.A4 Examples of amalgam pellets and amalgam mesh contained in fluorescent lamps.

Remove the fluorescent lamp carefully from the plastic housing using a knife or pliers as appropriate.

Let the fluorescent lamp leak slowly to atmosphere using procedure above A6.2, break open the tube and take out the amalgam pellet and the amalgam mesh from the fluorescent lamp.

Put them into a beaker and add 10 ml of aqua regia.

Heat for 90 minutes at 80°C.

After cooling the sample solution to room temperature, filter the solution through a 0.45 micron filter and transferred to an appropriate volumetric flask. Rinse the filter with water thoroughly and add water to marked line of a volumetric flask to make up the test solution (see note).

Note:

When the solution contains Bismuth, deposition of Bismuth may occur in accordance with a drop in acidity. Ensure aqua regia concentration exceeds 10% of the total volume within the volumetric flask.

A.6.3 SAMPLES FOR MEASUREMENT.

All samples are then transferred to 15 ml plastic tubes in an appropriate sample volume to the automated sampler on the ICP-OES. The volumes are recorded and appropriate blanks, duplicates and standard dilutions added to the sampling rack.

A.7 MEASUREMENT

A.7.1 INDUCTIVELY COUPLED PLASMA-OPTICAL EMISSION SPECTROPHOTOMETRY

A.7.1.1 General

After dissolving mercury from the lamp and/or amalgams by using nitric acid or other acids, the insoluble components are removed by filtering and the filtered solution made up to an appropriate volume. The appropriately diluted sample solutions are sprayed into plasma on the ICP-OES and the intensity of optical emission of mercury is measured and the mercury concentration for the whole lamp determined using procedures developed for the instrument.

A.7.1.2 Instruments

ICP-OES - The instrument that gives light emission intensity with suitable sensitivity and stability in the directed measurement and concentration range. This type of instrument is made by several manufacturers.

Gas: pure inert Argon gas as carrier gas into the plasma.

Note: See Figure 1 above for principle of ICP-OES.

A.7.1.3 Setting of measuring conditions

There is a possibility of memory effect when low mercury concentration sample is measured after a high mercury concentration sample. To avoid the memory effect, ensure that the rinse time is adequate. This is confirmed by analysing known standard solutions and determining that the concentration assayed is correct.

Note: Plasma output, photometric height, flow rate of carrier gas, etc. are varied to set for optimum conditions. These are determined by the trained instrument operator according to normal measurement conditions for the instrument at that time.

A.7.1.4 Quantitative analysis from the ICP-OES

Select the mercury analytical line at wavelength of 194.2 nanometres (nm) for measuring light emission intensity. When spectral interference is found not to exist, the analytical line at 253.7nm or the other spectral line may be used.

As any coexisting elements other than mercury in the sample solution could have spectral interference on the mercury analytical line, a mercury spectral line without spectral interference should be selected by scanning around the mercury analytical line with spraying sample solution into the plasma⁽¹⁾.

To avoid any effects of the phosphor in the matrix, a standard addition method should be used⁽²⁾. At least four solutions are sampled by an equal amount from the test solution to prepare one kind of solution wherein the mercury element is not added and at least three kinds of solutions wherein the mercury element is added respectively at different concentrations.

The solutions are sprayed into the plasma and the intensity of atomic emission of mercury is measured. The relation curve between the light emission intensity of the mercury element in the test solution is obtained from the intercept on the axis of abscissa (concentration).

Calculate the amount of mercury in the florescent lamp with the following formula:

$$W=A \times C \times V / 1000$$

Where, W : amount of mercury in fluorescent lamp (mg)

A : dilution rate

C : mercury concentration of test solution ($\mu\text{g Hg/ml}$)

V : amount of test solution (ml)

Notes

⁽¹⁾ As the line spectrum and continuous spectrum by a plasma composing component and a coexisting element are occasionally superimposed with each other for the analytical line as spectral interference, it is recommended that an analytical line with no spectral interference should be used. When spectral interference exists, the degree of the interference calculated as the concentration of mercury should be less than 1/100 of the concentration of mercury of the test solution by using a synthetic matrix solution.

⁽²⁾ This method can be applied only to the case of no spectral interference, or where the background and the spectral interference are regularly corrected and the calibration line between the light emission intensity and the concentration remains linear in the low concentration area or area required for measurement (see Figure 5)

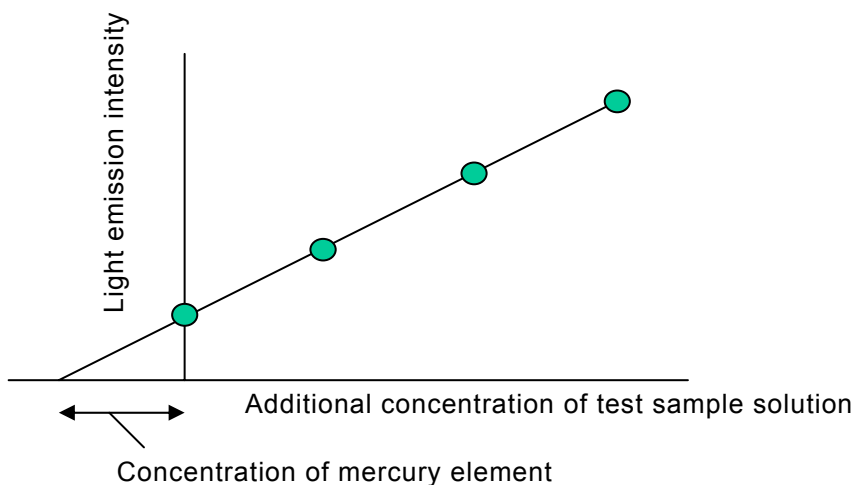

Fig. A5 Method for obtaining concentration by standard additional method

A.8 REPORTING

All results from the measurement of solutions and all calculations should be recorded onto test sheets. The results are determined for the milligram amounts of mercury per lamp as an average of the three lamps used to determine the concentration for each particular type of lamp. All results should be recorded on a suitable report indicating the results expressed as milligrams mercury per lamp and also contain the quality report determination of the results of any blanks or standards measured in the same determination. Results of reports and calculations should be checked by a second chemist.

A.8.1 MEASUREMENT UNCERTAINTY.

Ideally the three determinations of mercury per lamp should show good agreement with a measurement uncertainty of <10%. The standard deviation for the measurement can be determined from the measurements where there is good agreement in the three results. If there is not good agreement, the measurement uncertainty will be large and this may require that more than three lamps of the same type(eg 10 lamps) be tested to get a better standard deviation measure. Alternatively, poor agreement of three mercury results with the same type of lamp from the same manufactured batch may indicate uneven injection of Mercury into each lamp and poor manufacturing practice.

Annex B

Performance Mark

(Normative)

B.1 REQUIREMENT

When a compact fluorescent lamp (CFL) has a performance mark, the lamp shall be clearly and permanently marked with a numeral from the sequence I to X, indicating the performance of the CFL.

A CFL shall be marked with the appropriate numeral when it meets, or exceeds, the efficiency requirements associated with that numeral at all voltage and frequency values it is designed to operate at. The associated requirements for each numeral are shown in Table A1.

TABLE A1

PERFORMANCE REQUIREMENTS FOR EACH NUMERAL

Mark	Performance Level
I	Used if it does not meet any of the following criteria
II	t.b.a
III	t.b.a
IV	t.b.a
V	t.b.a
VI	t.b.a
VII – X	Reserved for future use

B.2 DESIGN OF THE PERFORMANCE MARK

The characteristics of the mark shall conform to the following description:

Format: Roman numeral: I, II, III, IV, V, VI, VII, VIII, IX or X.

Numerals VI to X are reserved for future use.

Font: Times Roman preferred, but other plain serif fonts are acceptable

Colour: Text to contrast with the background colour.

Placement: On the CFL, with the exact location to be at the discretion of the manufacturer.

The mark shall be legible and indelible

An example of the mark is shown in Figure A1.

FIGURE B1 EXAMPLE OF NUMERAL INDICATING PERFORMANCE



Annex C

Test Report (informative)

The following information shall be recorded in the test report:

1.1 Appliance (equipment) details:

- (a) brand, model, type, and serial number.
- (b) product description, *as appropriate*
- (c) rated voltage(s) and frequency(frequencies)
- (d) details of manufacturer marked on the product (if any)

1.2 Test Parameters

- (a) ambient temperature (°C).
- (b) test voltage(s) (V) and frequency (frequencies) (Hz).
- (c) total harmonic distortion of the electricity supply system
- (d) information and documentation on the instrumentation, set-up and circuits used for electrical testing.

1.3 Measured data

To be added

1.4 Test and laboratory details

- (a) test report number/reference
 - (b) date of test
 - (c) laboratory name and address
 - (d) test officer(s)
-